

ELECON SUPER SERIES IN WORM GEAR UNITS



Super NUSeries

ELECON 
Always a step ahead in technology

Ever since Elecon's inception 48 years ago, they have strived to reach new frontiers of technical excellence. From a modest start in manufacturing material handling equipment namely ELEVATORS & CONVEYORS in 1951, Elecon graduated to the manufacture of gear boxes (initially for captive use) in 1963. Today, Elecon's name become synonymous with high quality gear and material handling equipment in India.

Elecon had set up a separate Gear Division in 1976. This division has a capacity of producing more than 25,000 gear unit yearly, out of which 90% share for worm speed reduction gear units and remaining share in helical speed reduction gear unit. The gear units are working satisfactorily in cement, chemical, plastic, paper, power generation, sugar, textile, thermal plant industries.

Elecon have a wide range of worm, parallel shaft and right angle helical – spiral bevel speed reduction gear units.

Elecon have many firsts to their credit. In the eighties, they were the first to introduce casehardened and ground gear technology in India and the modular design concept for gear manufacture in India, as a result of which economical mass production and comprehensive maintenance of component stocks were made possible.

The latest additions to their production line are planetary gear boxes for marine and other applications which have already been delivered for use on the off-shore patrol vessels of the Indian Coast Guard. These are very compact, high precision gear boxes, capable of transmitting up to 23,000 KW of power.

For a forward-looking organisation like Elecon, modernisation is the watchword. That is precisely why they continuously update their production technology through frequent capital and infrastructural investments. Elecon have geared themselves for tomorrow by setting up one of the largest EDP centres in the Indian Engineering Industry. More than 85% of their machinery is computer controlled, ensuring a high degree of precision in the manufacture, design and testing of gear components. Apart from a large concentration of computerised numerically controlled (CNC) machines, they have flexible machining systems, a battery of modern quality control equipments for checking gear component's various parameters and geometry, on-line computerised inventory control, production planning and execution programmes. All this has resulted in Elecon's Gear Division being the most modern in the country – a fact that is unanimously acknowledged throughout the industry. Just as it is acknowledged by clients that Elecon, despite their stature and focus on modernisation, have not lost sight of their primary goal - customer satisfaction.

ISO – 9001 for Elecon Gear Division

In November 1994, the RW – TUV Germany has accredited that Elecon Gear Division Quality Management System confirms to the internationally accepted ISO 9001 standards. This certificate covers Quality Assurance in Design and Development, Production, Installation and Service of mechanical transmission products like Worm, Helical and special gear units, Fluid , Geared and Flexible couplings and Accessories.

WORM REDUCTION GEAR UNIT IN THE RANGE

Worm speed reduction gear unit is the result of more than thirty years of continuous efforts in development and refinement by ELECON ENGINEERING CO., the India's most experienced organisation in gear transmission engineering.

*** MODEL & TYPE : SNU – MODULAR UNIVERSAL MOUNTING – (SUPER NU SERIES)**

- Underdriven (SNU-U)
- Overdriven (SNU-O)
- Vertical output shaft up/down (SNU-V)
- Hollow output shaft (SNU-SM)

SIZES : $1\frac{5}{8}$, $1\frac{3}{4}$, 2, $2\frac{1}{4}$, 3, $3\frac{1}{2}$, 4, 5, 6, 7, 8, 9, 10.5

RATIO : Min. 5 : 1 to Max. 70 : 1

Power capacity to 139 KW

*** MODEL & TYPE : HEVY DUTY GEAR UNITS - SFU, SFO, SFV, SSM (SUPER SERIES)**

- Underdriven (SFU)
- Overdriven (SFO)
- Vertical output shaft up/down (SFV)
- Hollow output shaft (SSM)

SIZES : 12, 14, 17

RATIO : Min. 5 : 1 to Max. 70 : 1

Power capacity to 350 KW

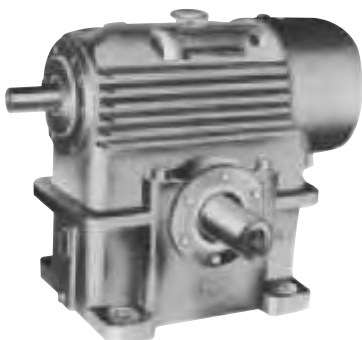
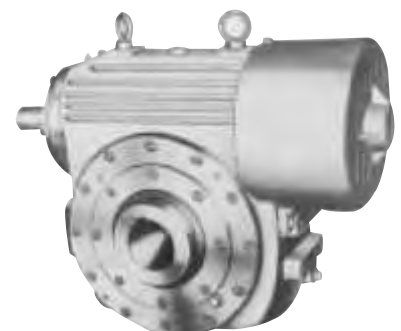
**SFU****SFO****SFV****SSM**

* **MODEL & TYPE : WORM GEARED MOTOR – SWM**

SIZES : 1 $\frac{3}{4}$, 2 $\frac{1}{4}$, 3, 4

RATIO : Min. 5 : 1 to Max. 70 : 1

OTHER SIZES CAN BE SUPPLIED ON REQUEST.

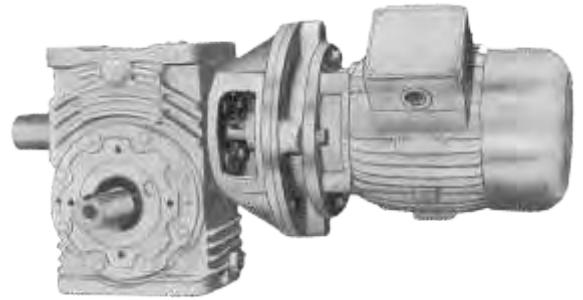

SWM

* **DOUBLE REDUCTION UNITS (WORM/WORM)**

A) MODEL & TYPE : SNU - MODULAR UNIVERSAL MOUNTING

Underdriven **(SNU-UD)**

Overdriven **(SNU-OD)**

Verticle output shaft up/down **(SNU-VD)**

Hollow output shaft **SNU-SMD**

Sizes : 1 $\frac{3}{4}$ / 30, 2 $\frac{1}{4}$ / 40, 2 $\frac{1}{4}$ / 50, 3/60,
3/70, 4/80, 4/90, 5/105

Ratio : Min. 75 : 1 to Max 4900 : 1

Power Capacity to 50 KW.



SNU-UD

B) MODEL & TYPE :

Underdriven **(SFUD)**

Overdriven **(SFOD)**

Verticle output shaft up/down **(SFVD)**

Hollow output shaft **(SSMD)**

Sizes : 5/120, 6/140, 7/170

Ratio : Min. 75 : 1 to 4900 : 1

Power Capacity to 60 KW.



SFUD

* **DOUBLE REDUCTION UNITS (HELICAL/WORM)**

MODEL & TYPE : Combination with First pair helical gear unit and Second pair with worm gear unit.

Underdriven	(HSFU)
Overdriven	(HSFO)
Vertical output shaft up/down	(HSFV)
Hollow output shaft	(HSSM)

SIZES : 7, 8, 9, 10.5, 12, 14

RATIO : Max. 440 : 1

Power Capacity to 70 KW.

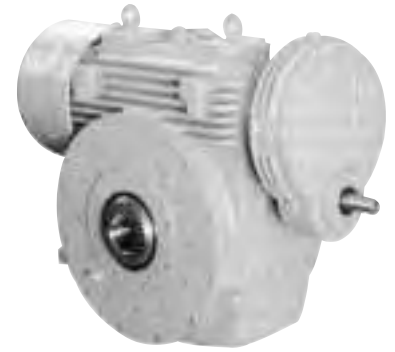

HSSM

* **Heavy Duty Stirrer Units**

Heavy Duty stirrer unit incorporates an extended bearing housing to accommodate a larger bottom bearing and increased shaft size, there by enhancing the unit capacity to absorb the high bending loads imposed during stirrer applications. This gear unit is compact with facility of top mounted pivoted platform where electric motor can be directly mounted above the gear unit using belt tensioning device.

MODEL & TYPE : SNU-CVDM

SIZES : 4, 5, 6, 7, 8, 9, 10.5

MODEL & TYPE : CVDM

SIZES : 12, 14, 17

RATIO : Min. 5 : 1 to Max, 70 : 1

Power Capacity to 350 KW

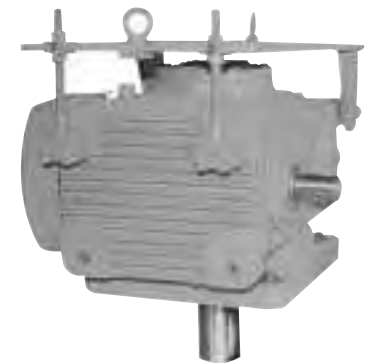

SNU-CVDM/CVDM

* **Cooling Tower Fan Drive Gear Unit**

Cooling Tower Fan Drive Gear Unit incorporates an extended top bearing housing to accommodate the larger wheel shaft bearing.

Length of the output shaft extension are manufactured to client's requirements and to suit fan hub mounting.

Lubrication is entirely contained by splash and lower bearing dip in the oil bath while oil is pumped to the top wheel shaft bearing by mean of a built in plunger mechanism. All exposed parts other than the extensions are applied with corrosion resistant paint.

MODEL & TYPE : SNU-CTU

SIZES : 4, 5, 6, 7, 8, 9, 10.5

MODEL & TYPE : CTU

SIZES : 12, 14, 17

RATIO : Min. 5 : 1 to Max. 70 : 1

Power Capacity : 350 KW



SNU-CTU/CTU

SUPER SERIES IN WORM GEAR UNITS

SPECIFICATIONS

GENERAL

Elecon single reduction gear units are the result of many years of experience. Completely re-designed gear case with liberal ribbing increases heat dissipating area, streamlined sump carrying more oil and larger capacity of fan enhance the thermal rating of the gearbox. All this means that the continuous load carrying capacity is increased without substantial rise in temperature.

No more opening of gearbox for hand changing, just replace the fan and fancowl from one end to other end of worm shaft.

DESIGN STANDARDS

Wherever applicable, British as well as Indian standards are used. Worm conforms to casehardening alloy steel, worm wheel conforms to phosphor-bronze PB2-C as per British Standard B.S. 1400, while gear case conforms to C. I. grade FG 220 and for heavy duty FG 250, Indian Standard I.S. 210.

GEAR CASE

Gear case is of streamlined design, rugged in construction, made of close-grain cast iron. It is completely oil-tight, dust-proof and capable of being installed in the open without a separate cover. The faces and bores are accurately bored and machined on latest precision machines to ensure perfect alignment and interchangeability.

WORM/WORM WHEEL

The worm is made of case-hardening alloy steel, carburised, ground and polished and is integral with the shaft. Bearing journals are accurately ground. Worm wheel is made of centrifugally cast phosphor-bronze rims, shrink fitted and brazed with C.I. centres.

Worms are generated on special-purpose worm milling machines, gas carburised and ground on automatic work grinders.

Worm wheels are hobbled on precision hobbing machines with high accuracy hobs. Each and every wheel is checked to match with the master worms to ensure complete interchangeability.

Right-hand threads are provided, unless otherwise specified.

BEARINGS

The worms and worm wheels are supported on ball or roller anti-friction bearings of ample margin of safety to allow adequate journal as well as thrust loads. Overhung loads arising out of sprocket or pinion drive are generally permissible because the gear case and bearings are

designed for this duty. However, complete details should be given to us for confirmation. In cases of heavy overhung loads, an extra roller bearing can be provided.

WHEEL SHAFT

The wheel shaft is made of high tensile carbon steel. It is of large diameter to carry the torsional as well as bending loads which may be induced by overhung drives.

LUBRICATION

Lubrication to gears and bearings is by splash of oil from the sump. Thus, no special care is required except for the occasional topping up of the oil to the required level. A large oil filler-cum-breather and inspection cover is provided together with a drain plug and ventilator. Neoprene lip-type oil seals are fitted on input and output shaft.

For very low input speed below 50 rpm. and heavy loads in sizes larger than 14" size forced lubrication is required. In such cases Elecon must be consulted.

COOLING

Air cooling is effected by means of standard polypropylene or metal fans which direct a continuous flow of air over the ribbed surface of the gear unit. The fan is designed to operate in both direction of rotation, and is so arranged in conjunction with the ribbing on the gear unit as to allow maximum heat dissipation.

HOLDBACK

Elecon Sprag type holdback can be fitted on all sizes of gears to prevent reverse rotation. In cases where holdback is required, the direction of rotation of the shaft should be mentioned.

POWER RATINGS

The ratings indicated in the catalogue holds good for 12 hours of continuous running under uniform load being driven by electric motor. They give minimum gear life of 26,000 hours, subject to limitation of maximum oil temperature of 100°C under full load, 20°C ambient.

OVERLOADS

All the components of the reduction gears are so designed that they can withstand.

- * 100 per cent overload for 15 seconds
- * 50 per cent overload for one minute
- * 40 per cent overload for 30 minutes and
- * 25 per cent overload for two hours.

Super NU *Series* MODULAR WORM GEAR UNIVERSAL MOUNTING

Further to successful launching of ELECON 'NU' Modular worm gearboxes, "SUPER NU" series is one step ahead in WORM GEAR TECHNOLOGY.

A combination of present-day concepts, analytical calculations with the help of CAD (Computer Aided Design) carried out on single part use of very latest CNC machine tools plus systematic checks on materials and workmanship, give this series of gearboxes a marked degree of reliability.

Single piece universal casing having flanges top and bottom side and also provision for a supporting flange make it possible to have the universal mounting positions for gearboxes such as underdriven, overdriven and vertical. The internal components are, therefore, interchangeable for all the mounting positions.

Quick change of mounting positions from underdriven to overdriven and vice versa merely by putting the unit upside down and replacing the positions of drain plug, breather plug and oil level indicator.

Comprehensive maintenance of stock and faster delivery can be achieved due to adoption of interchangeably principle. Robust compact and streamlined design with ample thermal capacities.

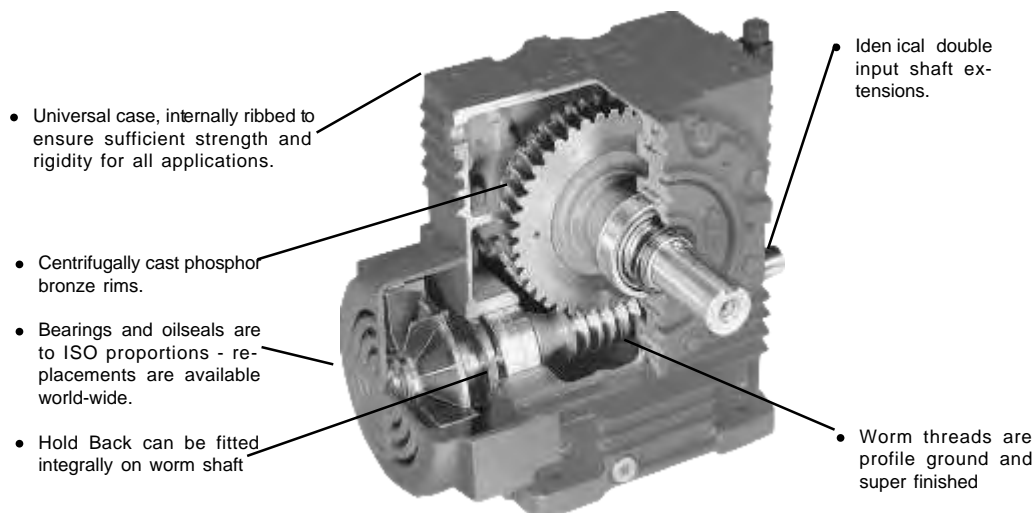

FILL AND FORGET Concept

The low and medium power gearunit sizes $1 \frac{5}{8}$, $1 \frac{3}{4}$, 2, $2 \frac{1}{4}$ and 3 are supplied with factory filled SYNTHETIC LUBRICANT and require no lubricant maintenance. User has not to fill any grade of lubricant.

Change or shaft handling

This is achieved easily and quickly by just replacing the cap from one end of the worm shaft only in the case of $1 \frac{5}{8}$, $1 \frac{3}{4}$, 2, $2 \frac{1}{4}$ and 3 SNU gear units. It is not necessary to dismantle the complete gear unit. While in 4 SNU onwards, just replace the fan and fancowl from one end to other end of the worm shaft.

TABLE NO. 1 LOAD CLASSIFICATION BY APPLICATIONS

Driven Machine	Type of Load	Driven Machine	Type of Load
Agitators & mixers		Reciprocating	H
Pure Liquids, semi-liquids	U	Screw	M
Liquids and solids variable density	M	Food Industry	
Liquids with variable density	M	Beef slicer	M
Blowers		Cereal cooker	U
Centrifugal, vane	U	Laundry machines	
Lobe	M	Washers, tumblers	M
Brewing & distilling		Line shaft	M
Bottle machinery	U	Mills	
Brew kettle continuous duty	U	Hammers	H
Cookers, scale hopper	M	Ball kilns, pebbles	M
(frequent starts)		Rod tumbling barrels	H
Cane filling Machinery	U	Cement kilns	M
Cane knives	M	Dryers and coolers	M
Clarifiers*	U	Mixers	
Classifiers	U	Concrete mixers	M
Clay-working machinery		Sugar industry	
brick press, briquette machine	H	Cane knives	M *
Pug mill, clay-working machinery	M	Crushers	M *
Compressors		Mills	H *
Centrifugal	U	Oil industry	
Lobe	M	Chillers	M
Reciprocating multi-cylinder	M	Rotary kilns	M
Reciprocating single-cylinder	H	Paper mill	
Conveyors - Uniformly loaded or fed		Bleacher conveyor press, winder	
Apron, Belt, Bucket, Screw	U	Calendars, agitators, beater and pulper	M
Conveyors - Heavy Duty - Not Uniformly fed		Pumps	
Apron, Belt, Bucket, Screw	M	Centrifugal	U
Reciprocating and shaker	M	Reciprocating (three or more cylinders)	M
Cranes		Gear, lobe type	U
Main Hoist	M	Rubber & plastic industry	
Bridge Travel	*	Crackers	H *
Crushers		Fixing mills	H *
Ore, Stone	H	Laboratory equipment	M
Sugar	M	Refiners	M *
Elevators		Sheeters	M *
Bucket-uniform load	U	Tubers and strainers	M *
Bucket-heavy load	M	Warming mills	M *
Bucket-continuous load	U	Tyre and Tube press	M *
Centrifugal discharge	U	Sand Mullers	M
Gravity discharge	U	Screens	
Passenger lifts	*	Air washing	U
Fans		Rotary-stone / gravel	M
Centrifugal	U	Textile industry	
Induced draft	M	Batches	M
Large (mine, industrial, etc.)	M	Calendars	M
Light (small diameter)	U	Dyeing machinery	M
Cooling Towers	H	Spinners	M
Induced draft	*	Washers	M
forced draft	*	Winders	M
Feeders		Wire-drawing, Flattening machine	M
Apron	M	Wire Winding machine	M
Belt	M		
Disc.	U		

* Should be selected on the basis of 24 hours / day service only & consult Elecon.

ENQUIRY

1. Type of prime mover, KW rating, speed R.P.M.
2. Required reduction ratio & Handing.
3. Type of driven machine, actual power required, designed speed R.P.M., peak and shock (give magnitude and duration where possible).
4. Type of drive employed between
 - (i) Prime mover and reducer.
 - (ii) Reducer and driven machine
5. No. of hours / day the gear unit will be in operation.
6. Ambient conditions, i.e., temperature, humidity.
7. Whether holdback required ? Specify direction of rotation, if holdback is to be fitted.
8. Details of any external loads imposed on gear unit.
9. Give sketch of available space.

Explanation and use of ratings and service factors.

Gear unit selection is made by comparing actual loads with catalogue ratings. Catalogue ratings are based on a standard set of loading conditions whereas actual load conditions vary according to type of application. Service factors are therefore used to calculate an equivalent load to compare with catalogue ratings.

* Mechanical ratings and service factor (F_M)

Mechanical ratings measure capacity in terms of life and/or strength assuming 12 hr/day continuous running under uniform load conditions.

Catalogue ratings allow 100% overload at starting, breaking or momentarily during operations up to 12 hours per day.

TABLE NO.2 Mechanical service factor (F_M)

Prime mover	Duration of service hrs per day	Load classification - driven machine		
		Uniform	Moderate Shock	Heavy Shock
Electric motor, steam turbine or hydraulic motor	Under : 3	0.80	1.00	1.50
	3 to 10	1.00	1.25	1.75
	Over 10 to 24	1.25	1.50	2.00
Multi-cylinder internal combustion engine	Under : 3	1.00	1.25	1.75
	3 to 10	1.25	1.50	2.00
	Over 10 to 24	1.50	1.75	2.25
Single cylinder internal combustion engine	Under : 3	1.25	1.50	2.00
	3 to 10	1.50	1.75	2.25
	Over 10 to 24	1.75	2.00	2.50

- For Units subject to frequent starts/stops and overloads, also applications where high inertia loads are involved e.g. crane travel drives, slewing motion etc. consult Elecon.

* Thermal ratings and Thermal service factor (F_T)

Thermal ratings measure a unit's ability to dissipate heat, if they are not exceeded, the lubricant may overheat and break down resulting in failure of gear unit.

Thermal ratings are affected by ambient temperature and not by mechanical considerations such as increased running time and shock loads.

Catalogue ratings are given on 20°C ambient temperature allowing for a lubricant temperature rise to 100°C during operation as the unit transmit power and generate heat.

Thermal ratings calculated with unit fan cooling.

Thermal service factor F_T (Table No. 3) is used to modify the actual load according to prevailing ambient temperature.

TABLE NO. 3 THERMAL SERVICE FACTOR (F_T)

Ambient Temp °C	10	20	30	40	50	60
Factor	0.87	1.00	1.16	1.35	1.62	1.97

If the ambient temperature is other than 20°C, divide the catalogue thermal rating by the factor from Table No. 3

STEP : 5 From catalogue, rating at input 1500 rpm Ratio - 50:1, for 14 size
 Output torque (Thermal) = 10486.9 Nm, which is less than calculated equivalent
 Output torque (Thermal) = 11460 Nm
 Higher gear unit size 17 SFU, Ratio - 50:1 is to be selected where at input 1500 rpm
 Where, Output torque (Mechanical) = 29064 Nm and
 Input power (Mechanical) = 110 KW
 Required Input power

$$= \frac{\text{Calculated equivalent output torque (Mech.)} \times \text{Rated power (Mech.)}}{\text{Rated output torque (Mech.)} \times F_m}$$

$$= \frac{14818.96 \times 110}{29064 \times 1.5} = 37.39 \text{ KW}$$
 Nearest standard motor having 37 KW at 1500 rpm can be selected for the application.

EXAMPLE - 3

Worm reduction gear (underdriven type) required to drive a clay-working machine for continuous 10 hours/day. The power required at clay-working machine is 5 KW at 50 rpm, ambient temperature is 40°C. Also suggest an electric motor power at 1500 rpm to drive the gear unit.

SOLUTION :

STEP : 1 Ratio required = $\frac{\text{Input speed}}{\text{Output speed}} = \frac{1500}{50} = 30:1$

STEP : 2 From Table No.1
 Driven m/c - Clay-working machinery, Type of Load - Moderate shock (M),
 From Table No.2
 Mechanical service factor (Fm) = 1.25 for 10 running hrs/day continuous
 From Table No.3
 Thermal service factor (Ft) = 1.35 at 40°C ambient temp.
 The higher of the abovetwo service factor i.e. 1.35 is to be considered as a service factor.

STEP : 3 Equivalent output power = 5 KW x 1.35 = 6.75 KW

Equivalent output torque = $\frac{9550 \times 6.75}{50} = 1289.25 \text{ Nm}$

STEP : 4 From catalogue, Refer rating at Input speed 1500 rpm, Ratio - 30:1
 Gear unfit size 6 SNU-U, Ratio 50:1 having

Input power = 12.2 KW

Output torque = 1980.7 Nm

STEP : 5 Required Input power

$$= \frac{\text{Calculated equivalent output torque} \times \text{Rated input power}}{\text{Rated output torque} \times \text{Service factor}}$$

$$= \frac{1289.25 \times 12.2}{1980.7 \times 1.35} = 5.88 \text{ KW}$$

Suggest nearest standard A.C. electric motor having 7.5 KW at 1500 rpm to drive gear unit size 6 SNU-U, Ratio 30:1.

RATINGS AT INPUT SPEED 1500 R.P.M.

GEAR RATIO	OUTPUT SPEED R.P.M.	CAPACITY	SIZE OF UNIT				
			1 $\frac{5}{8}$	1 $\frac{3}{4}$	2	2 $\frac{1}{4}$	3
5	300	INPUT POWER KW	1.46	2	2.9	3.8	8
		OUTPUT TORQUE Nm	44.2	56.6	83.1	112.5	231.8
7.5	200	INPUT POWER KW	1.3	1.45	2.2	3	6.86
		OUTPUT TORQUE Nm	54.6	61	92.4	127	294.8
10	150	INPUT POWER KW	1.2	1.3	1.75	2.8	5.75
		OUTPUT TORQUE	69.5	74.5	97	146	325.8
15	100	INPUT POWER KW	1.14	1.2	1.6	1.9	4.13
		OUTPUT TORQUE Nm	90.36	96.3	122.2	154.2	347.1
20	75	INPUT POWER KW	0.8	0.83	1.5	1.62	3.78
		OUTPUT TORQUE Nm	86.6	88.8	149	161	404.3
25	60	INPUT POWER KW	0.7	0.72	1.3	1.44	3.15
		OUTPUT TORQUE Nm	79.1	90	155.1	176.5	411.1
30	50	INPUT POWER KW	0.6	0.63	1.15	1.3	2.75
		OUTPUT TORQUE Nm	85.6	91.5	160.3	186.2	430.7
40	37.5	INPUT POWER KW	0.45	0.5	0.8	0.97	2.27
		OUTPUT TORQUE Nm	88	94.3	146.7	177.9	439.4
50	30	INPUT POWER KW	0.34	0.36	0.65	0.72	1.82
		OUTPUT TORQUE Nm	70.4	78	145	160.4	423
60	25	INPUT POWER KW	0.3	0.31	0.45	0.55	1.6
		OUTPUT TORQUE Nm	58.5	75.8	110	140.7	434
70	21.4	INPUT POWER KW	0.26	0.27	0.4	0.43	1.3
		OUTPUT TORQUE Nm	58.1	74	107	124.7	406.1

GEAR RATIO	OUTPUT SPEED R.P.M.	CAPACITY	SIZE OF UNIT						
			3.54	4	5	6	7	8	9
5	300	INPUT POWER KW	12.5	14.1	23.5	41	55	72	82.4
		OUTPUT TORQUE Nm	362.1	420.1	710.6	1253	1646.6	2177.4	2491.2
7.5	200	INPUT POWER KW	8	10	18.2	27	43.2	58	63.4
		OUTPUT TORQUE Nm	343.8	444.1	820	1211.9	1935	2603	2933.2
10	150	INPUT POWER KW	7	8.5	16.5	24	33.1	46	74.5
		OUTPUT TORQUE Nm	392.2	503.3	966.5	1444	1952.3	2753	4506
15	100	INPUT POWER KW	6	7	12	21.5	30	40	56
		OUTPUT TORQUE Nm	492.8	568.2	986	1827.4	2580	3514.4	5027
20	75	INPUT POWER KW	4.6	6.1	11.5	16.2	25.8	31.2	48
		OUTPUT TORQUE Nm	503.7	652.8	1205.2	1836.8	2814	3496.1	5447.3
25	60	INPUT POWER KW	4	5	9	13	20	28	42
		OUTPUT TORQUE Nm	547.5	684.4	1218.3	1810.5	2706	3788.2	6061.5
30	50	INPUT POWER KW	3.6	4.5	7.5	12.2	17	23	40
		OUTPUT TORQUE Nm	550	747.8	1217.6	1980.7	2760	3778	6876
40	37.5	INPUT POWER KW	2.8	3.8	5.8	10.4	15	20	32
		OUTPUT TORQUE Nm	549.1	754.8	1168	2118.8	3132.4	4278.4	7253
50	30	INPUT POWER KW	2.1	3	5	8.5	13	17	27
		OUTPUT TORQUE Nm	508	764	1257.4	2088.4	3228	4437.5	7220
60	25	INPUT POWER KW	1.8	2.6	4.2	7	11	14	22
		OUTPUT TORQUE Nm	515.7	739.9	1171.2	2032.2	3193.5	4011	6597
70	21.4	INPUT POWER KW	1.13	2.3	3.6	5.8	8.5	11.3	19
		OUTPUT TORQUE Nm	462.3	759.5	1124.6	1811.8	2769.1	3782	6868

- The Ratings are based on service factor of 1, continuously transmitted for 12 hours/day with normal overload of 100% momentarily for 15 seconds, 40% for 30 minutes, 25% for 2 hours.
- See Page No. 9 for actual service factor to nature of load and duration of operation.
- Ratios and output speeds are nominal. Exact ratios are listed on Page No. 30
- Higher rating can be obtained by using SYNTHETIC OIL, details on Page No. 32

RATINGS AT INPUT SPEED 1500 R.P.M.

GEAR RATIO	OUTPUT SPEED R.P.M.	CAPACITY	SIZE OF UNIT				
			10	10.5	12	14	17
5	300	INPUT MECH. POWER (KW)	123	139.3	196.3	274.3	*
		OUTPUT MECH. TORQUE (Nm)	3700.0	4260.2	5493.6	8224.7	*
		INPUT THERMAL POWER (KW)	90	94.03	119.4	162	*
		OUTPUT THERMAL TORQUE (Nm)	2707.7	2843.6	3776.85	4857	*
7.5	200	INPUT MECH. POWER (KW)	92	94	128	184	*
		OUTPUT MECH. TORQUE (Nm)	4129.4	4309	5699.61	8279.6	*
		INPUT THERMAL POWER (KW)	76	84.3	108.6	150	*
		OUTPUT THERMAL TORQUE (Nm)	3411.3	3845.5	4806.9	6674.7	*
10	150	INPUT MECH. POWER (KW)	65	84	110.5	162.4	320
		OUTPUT MECH. TORQUE (Nm)	3807.3	4920.2	6557	9635.4	19354.6
		INPUT THERMAL POWER (KW)	62	79.1	98.7	141	200
		OUTPUT THERMAL TORQUE (Nm)	3631.5	4748	6464.6	8358.1	12224
15	100	INPUT MECH. POWER (KW)	58	63	81	150	249
		OUTPUT MECH. TORQUE (Nm)	4985.1	5535.2	7131.87	13349.4	21877
		INPUT THERMAL POWER (KW)	56	60.4	76	110	177
		OUTPUT THERMAL TORQUE (Nm)	4813.2	5454.4	6670.8	9790.8	15720.5
20	75	INPUT MECH. POWER (KW)	55	55.2	75	123	216
		OUTPUT MECH. TORQUE (Nm)	6303.3	6393.2	8619	14288.3	25028.6
		INPUT THERMAL POWER (KW)	48	49	63	94.3	160
		OUTPUT THERMAL TORQUE (Nm)	5500.8	5615.4	7239.8	10954.8	18366
25	60	INPUT MECH. POWER (KW)	45	48	67.5	110	172
		OUTPUT MECH. TORQUE (Nm)	6303.0	6723.2	9380.3	14695.4	24365.2
		INPUT THERMAL POWER (KW)	39	41.1	50	71.6	135
		OUTPUT THERMAL TORQUE (Nm)	5462.6	5846.7	6948.4	9947.3	19124
30	50	INPUT MECH. POWER (KW)	40	42	56	92	158
		OUTPUT MECH. TORQUE (Nm)	6494.0	7059.3	9339.1	14652.2	26556.6
		INPUT THERMAL POWER (KW)	32	34	45	61.2	121
		OUTPUT THERMAL TORQUE (Nm)	5195.2	5714.7	7504.65	9761	20337
40	37.5	INPUT MECH. POWER (KW)	34	36	51.	76	119
		OUTPUT MECH. TORQUE (Nm)	7359.9	7793	10830.2	16137.4	26062.6
		INPUT THERMAL POWER (KW)	25	29	37	48	93
		OUTPUT THERMAL TORQUE (Nm)	5411.7	6277.5	7857.8	10192.6	20131.4
50	30	INPUT MECH. POWER (KW)	28	32	44	62	110
		OUTPUT MECH. TORQUE (Nm)	7130.7	8455	11404.1	16457.4	29064
		INPUT THERMAL POWER (KW)	22	25	31	39.5	81.6
		OUTPUT THERMAL TORQUE (Nm)	5602.7	6764	8740.7	10486.9	21300.32
60	25	INPUT MECH. POWER (KW)	24	27.4	37	54.8	78
		OUTPUT MECH. TORQUE (Nm)	7242.7	8373	11092.2	17520.6	25326.6
		INPUT THERMAL POWER (KW)	18	21.45	28	33.6	45.2
		OUTPUT THERMAL TORQUE (Nm)	5432.0	6555	8397.4	10702.7	17712.6
70	21.4	INPUT MECH. POWER (KW)	21	24.5	32	46	75
		OUTPUT MECH. TORQUE (Nm)	7309.8	8528	11207	16716.2	27445
		INPUT THERMAL POWER (KW)	20	19.2	22.5	28.4	57.3
		OUTPUT THERMAL TORQUE (Nm)	6961.7	6683.2	7880.4	10320.1	20456.6

- The Ratings are based on service factor of 1, continuously transmitted for 12 hours/day with normal overload of 100% momentarily for 15 seconds, 40% for 30 minutes, 25% for 2 hours.
- See Page No. 9 for actual service factor to nature of load and duration of operation.
- Ratios and output speeds are nominal. Exact ratios are listed on Page No. 30
- Higher rating can be obtained by using SYNTHETIC OIL, details on Page No. 32

For rating marked * consult ELECON

RATINGS AT INPUT SPEED 1000 R.P.M.

GEAR RATIO	OUTPUT SPEED R.P.M.	CAPACITY	SIZE OF UNIT				
			1 $\frac{5}{8}$	1 $\frac{3}{4}$	2	2 $\frac{1}{4}$	3
5	200	INPUT POWER KW	1.17	1.3	2.8	3	6.1
		OUTPUT TORQUE Nm	55.9	54.6	119	129.6	262.1
7.5	133	INPUT POWER KW	0.95	0.98	1.95	2.4	5.23
		OUTPUT TORQUE Nm	58	60.5	122.8	155	338
10	100	INPUT POWER KW	0.85	0.9	1.57	1.65	4.58
		OUTPUT TORQUE Nm	72.4	70.5	137.9	141.8	389.3
15	66.7	INPUT POWER KW	0.82	0.85	1.5	1.6	3.84
		OUTPUT TORQUE Nm	103.3	96.1	195.4	208.5	483.8
20	50	INPUT POWER KW	0.7	0.8	1.45	1.55	2.8
		OUTPUT TORQUE Nm	107	119.2	213.3	236.8	470.6
25	40	INPUT POWER KW	0.6	0.72	1.18	1.3	2.33
		OUTPUT TORQUE Nm	114.6	123.8	210.71	232.8	472.8
30	33.4	INPUT POWER KW	0.54	0.6	0.85	1.21	2
		OUTPUT TORQUE Nm	112.7	121.8	177.4	256	468.9
40	25	INPUT POWER KW	0.42	0.54	0.73	0.82	1.88
		OUTPUT TORQUE Nm	112.3	136.1	189.6	216.1	574.5
50	20	INPUT POWER KW	0.3	0.4	0.6	0.73	1.45
		OUTPUT TORQUE Nm	70.2	122.2	182.8	226.6	498.5
60	16.7	INPUT POWER KW	0.24	0.31	0.39	0.49	1.26
		OUTPUT TORQUE Nm	67.25	113.5	127.1	161.2	490
70	14.3	INPUT POWER KW	0.2	0.22	0.33	0.39	1.12
		OUTPUT TORQUE Nm	65.5	88.2	127.8	148.5	486.2

GEAR RATIO	OUTPUT SPEED R.P.M.	CAPACITY	SIZE OF UNIT						
			3.54	4	5	6	7	8	9
5	200	INPUT POWER KW	10.56	12.2	22.2	32.23	46.5	59.1	64.4
		OUTPUT TORQUE Nm	451.8	553.4	1022.9	1462	2087.2	2717.6	2912
7.5	133	INPUT POWER KW	6.86	9.04	17	25	37	47.46	54.1
		OUTPUT TORQUE Nm	438.4	610.2	1147.4	1687.4	2497.4	3254.5	3682.1
10	100	INPUT POWER KW	6.6	7.8	14.59	22.4	28.24	38.5	48.5
		OUTPUT TORQUE Nm	554.7	692.8	1295.8	2010.8	2481.2	3492.9	4400
15	66.7	INPUT POWER KW	5	6.5	9.3	16.5	24.2	29.5	37.3
		OUTPUT TORQUE Nm	615.7	856.2	1225	2197.1	3187.7	3928.1	4966
20	50	INPUT POWER KW	4.3	6.2	8.8	13	17.5	24.2	30.8
		OUTPUT TORQUE Nm	698.1	1065.8	1462.3	2185	2874.6	3882.6	5471
25	40	INPUT POWER KW	3.15	5	7.1	10.2	15.6	21	27
		OUTPUT TORQUE Nm	601.7	1026.6	1440.9	2094.3	3203.1	4412.1	5673
30	33.4	INPUT POWER KW	2.9	4.2	6.2	9	14.23	18.8	23.2
		OUTPUT TORQUE Nm	646.8	1008.8	1524.6	2187.4	3417.8	4569.1	5722
40	25	INPUT POWER KW	2.5	3.72	4.9	7.8	11	14.5	20
		OUTPUT TORQUE Nm	716.3	1122.6	1516.2	2383.7	3445.6	4542	6417
50	20	INPUT POWER KW	1.8	2.6	4.2	6.6	9.6	13	15.4
		OUTPUT TORQUE Nm	601.6	918.7	1544.2	2426.7	3529.7	4966	5956.3
60	16.7	INPUT POWER KW	1.43	2.22	3.6	5.4	8.2	11	13.1
		OUTPUT TORQUE Nm	547.9	939.4	1482.3	2254.3	3423.1	4717.8	5993
70	14.3	INPUT POWER KW	1.21	2.16	3.13	4.6	6.9	8.88	10.1
		OUTPUT TORQUE Nm	484.8	980.9	1463.2	2089	3317.8	4210.5	5961.2

- The Ratings are based on service factor of 1, continuously transmitted for 12 hours/day with normal overload of 100% momentarily for 15 seconds, 40% for 30 minutes, 25% for 2 hours.
- See Page No. 9 for actual service factor to nature of load and duration of operation.
- Ratios and output speeds are nominal. Exact ratios are listed on Page No. 30
- Higher rating can be obtained by using SYNTHETIC OIL, details on Page No. 32

RATINGS AT INPUT SPEED 1000 R.P.M.

GEAR RATIO	OUTPUT SPEED R.P.M.	CAPACITY	SIZE OF UNIT				
			10	10.5	12	14	17
5	200	INPUT MECH. POWER (KW)	99.7	112.8	152.16	223	*
		OUTPUT MECH. TORQUE (Nm)	4570.2	5143.8	6835.2	9717.3	*
		INPUT THERMAL POWER (KW)	70	81.15	100	154	*
		OUTPUT THERMAL TORQUE (Nm)	3208.8	3681.5	4449.8	6710	*
7.5	133	INPUT MECH. POWER (KW)	72.4	83	110	152	*
		OUTPUT MECH. TORQUE (Nm)	4927.6	5649	7361.4	9834.5	*
		INPUT THERMAL POWER (KW)	57	60.44	80	132	*
		OUTPUT THERMAL TORQUE (Nm)	3879.5	4113.6	5353.3	8534.7	*
10	100	INPUT MECH. POWER (KW)	51	57.3	92	134	268
		OUTPUT MECH. TORQUE (Nm)	4480.9	5143.8	8187.4	11301.1	24310
		INPUT THERMAL POWER (KW)	49	54.5	70	111	160.5
		OUTPUT THERMAL TORQUE (Nm)	4305.1	4944.5	6229.3	9358.7	14101.53
15	66.7	INPUT MECH. POWER (KW)	45	50	68	125	220
		OUTPUT MECH. TORQUE (Nm)	5863.2	6657.8	8882.9	15627.3	28979.3
		INPUT THERMAL POWER (KW)	41	43.3	60	96.6	139.3
		OUTPUT THERMAL TORQUE (Nm)	5342.0	5579.6	7838.2	12076	18349.2
20	50	INPUT MECH. POWER (KW)	42	44.5	62	102	209.3
		OUTPUT MECH. TORQUE (Nm)	7139.6	7649.5	10565.4	16628	35528
		INPUT THERMAL POWER (KW)	33	34.3	49	83.5	132
		OUTPUT THERMAL TORQUE (Nm)	5609.7	5896.2	8358.1	13298.4	21430.2
25	40	INPUT MECH. POWER (KW)	33	36	53	80	128
		OUTPUT MECH. TORQUE (Nm)	6775.7	7735.5	11124.5	15921.6	27198
		INPUT THERMAL POWER (KW)	28	30	40	67	89
		OUTPUT THERMAL TORQUE (Nm)	5749.1	6446.25	8529.8	13361.22	189114
30	33.4	INPUT MECH. POWER (KW)	30	31	48	72.7	120
		OUTPUT MECH. TORQUE (Nm)	7399.1	7828.5	11883.8	17180.7	30973
		INPUT THERMAL POWER (KW)	24	26.86	35	58	80
		OUTPUT THERMAL TORQUE (Nm)	5919.3	6776.8	8665.2	13704.6	20419
40	25	INPUT MECH. POWER (KW)	26	28.7	42	60.2	80
		OUTPUT MECH. TORQUE (Nm)	8442.2	8770.1	13380.8	18953	26281.6
		INPUT THERMAL POWER (KW)	18.5	20.14	30.5	36	62
		OUTPUT THERMAL TORQUE (Nm)	6007.0	6385.6	9714.8	12135	20368.2
50	20	INPUT MECH. POWER (KW)	20.8	21.6	36	49	78
		OUTPUT MECH. TORQUE (Nm)	8243.6	8302.7	13488.7	19280.5	31285.8
		INPUT THERMAL POWER (KW)	16	17.91	24	34.5	60
		OUTPUT THERMAL TORQUE (Nm)	6341.2	6841.6	8986	13737	23779.5
60	16.7	INPUT MECH. POWER (KW)	17.5	19	30	39	72
		OUTPUT MECH. TORQUE (Nm)	8006.0	8475	13292.5	18600	34174
		INPUT THERMAL POWER (KW)	13	14.2	22	25.8	50
		OUTPUT THERMAL TORQUE (Nm)	5947.3	6338	9751.1	12301.7	23446
70	14.3	INPUT MECH. POWER (KW)	14.5	15.8	32	34	62
		OUTPUT MECH. TORQUE (Nm)	7262.7	8125	11207	17819.8	33538.5
		INPUT THERMAL POWER (KW)	12	13	19	21.6	43
		OUTPUT THERMAL TORQUE (Nm)	6010.5	6685	93352	12027	23260.6

- The Ratings are based on service factor of 1, continuously transmitted for 12 hours/day with normal overload of 100% momentarily for 15 seconds, 40% for 30 minutes, 25% for 2 hours.
- See Page No. 9 for actual service factor to nature of load and duration of operation.
- Ratios and output speeds are nominal. Exact ratios are listed on Page No. 30
- Higher rating can be obtained by using SYNTHETIC OIL, details on Page No. 32

For rating marked * consult ELECON

RATINGS AT INPUT SPEED 750 R.P.M.

GEAR RATIO	OUTPUT SPEED R.P.M.	CAPACITY	SIZE OF UNIT				
			1 $\frac{5}{8}$	1 $\frac{3}{4}$	2	2 $\frac{1}{4}$	3
5	150	INPUT POWER KW	0.98	1.14	1.8	2.1	4.04
		OUTPUT TORQUE Nm	54.7	63.5	110.6	117.3	234.1
7.5	100	INPUT POWER KW	0.77	0.8	1.34	1.45	3.5
		OUTPUT TORQUE Nm	60.5	63.4	110.1	123.9	310.9
10	75	INPUT POWER KW	0.58	0.65	1.12	1.24	3.21
		OUTPUT TORQUE Nm	60.6	67.9	119.8	137.4	372
15	50	INPUT POWER KW	0.52	0.53	0.85	0.93	2.16
		OUTPUT TORQUE Nm	72.5	81	128.3	151	350.7
20	37.5	INPUT POWER KW	0.45	0.48	0.76	0.86	1.85
		OUTPUT TORQUE Nm	78.6	95.4	151	170.8	391
25	30	INPUT POWER KW	0.38	0.42	0.56	0.75	1.7
		OUTPUT TORQUE Nm	78.6	97.6	139.1	181.5	432.9
30	25	INPUT POWER KW	0.36	0.38	0.48	0.6	1.5
		OUTPUT TORQUE Nm	82.5	101.6	135.7	176.5	435.5
40	18.8	INPUT POWER KW	0.32	0.36	0.4	0.45	1.4
		OUTPUT TORQUE Nm	89.4	124.4	138.2	160	526.3
50	15	INPUT POWER KW	0.24	0.28	0.32	0.39	1.28
		OUTPUT TORQUE Nm	79.5	94.5	138.5	168.8	570.5
60	12.5	INPUT POWER KW	0.2	0.23	0.28	0.31	1.12
		OUTPUT TORQUE Nm	79.5	87.9	139.1	154	564.8
70	10.7	INPUT POWER KW	0.16	0.18	0.2	0.26	0.87
		OUTPUT TORQUE Nm	75.7	88.4	108.9	150.8	520.3

GEAR RATIO	OUTPUT SPEED R.P.M.	CAPACITY	SIZE OF UNIT						
			3.54	4	5	6	7	8	9
5	150	INPUT POWER KW	7.15	10.47	17	24.03	32.61	42.91	45.48
		OUTPUT TORQUE Nm	409.7	619.9	1014.2	1442.7	1964.1	2592.6	2753.7
7.5	100	INPUT POWER KW	5.83	8.1	15.1	21.45	29.18	39.48	42.91
		OUTPUT TORQUE Nm	478.8	707.1	1333.9	1911.2	2600	3544.1	3864.3
10	75	INPUT POWER KW	5.52	6.3	11.59	16.91	23.17	30.04	36.04
		OUTPUT TORQUE Nm	611.5	722	1338.5	1916.4	2723.14	3538.2	4295.4
15	50	INPUT POWER KW	4.1	5.2	8	13.13	18.02	24.15	28.3
		OUTPUT TORQUE Nm	673.5	795	1333.7	2221.9	3118.3	4202.1	4884.4
20	37.5	INPUT POWER KW	3.5	3.7	6.44	10	13.5	18	23.2
		OUTPUT TORQUE Nm	737.1	782.8	1387.5	2181	2993.5	4001.7	5180.8
25	30	INPUT POWER KW	2.8	3.11	5.5	7.82	12.1	16.31	19.74
		OUTPUT TORQUE Nm	739.8	760.3	1267.6	2078.6	3270.2	4449.6	5423
30	25	INPUT POWER KW	2.3	2.75	4.8	7.4	11.33	14.08	17
		OUTPUT TORQUE Nm	682.3	772.1	1420.3	2252.5	3492.7	4335.1	5374.4
40	18.8	INPUT POWER KW	1.77	2.14	3.7	5.75	8.33	10.6	13.3
		OUTPUT TORQUE Nm	660.9	751.2	1336.5	2234.5	3228.6	4122.2	5371.1
50	15	INPUT POWER KW	1.47	1.81	3.17	5.15	8	9.44	11
		OUTPUT TORQUE Nm	627.1	790.5	1374.4	2347.6	3739.3	4501.6	5253.3
60	12.5	INPUT POWER KW	1.27	1.73	2.92	4.21	7	8.66	10
		OUTPUT TORQUE Nm	628.2	867.1	1470.2	2196.8	3632.1	4518.9	5737.5
70	10.7	INPUT POWER KW	1.12	1.46	2.58	3.61	5.5	7	8.4
		OUTPUT TORQUE Nm	599.8	831.4	1538.2	2255.4	3475.5	4572	5585.4

- The Ratings are based on service factor of 1, continuously transmitted for 12 hours/day with normal overload of 100% momentarily for 15 seconds, 40% for 30 minutes, 25% for 2 hours.
- See Page No. 9 for actual service factor to nature of load and duration of operation.
- Ratios and output speeds are nominal. Exact ratios are listed on Page No. 30
- Higher rating can be obtained by using SYNTHETIC OIL, details on Page No. 32

RATINGS AT INPUT SPEED 750 R.P.M.

GEAR RATIO	OUTPUT SPEED R.P.M.	CAPACITY	SIZE OF UNIT				
			10	10.5	12	14	17
5	150	INPUT MECH. POWER (KW)	105	108.65	146.12	200	*
		OUTPUT MECH. TORQUE (Nm)	6350.7	6571.5	8884.3	12173.1	*
		INPUT THERMAL POWER (KW)	75	78.23	97.5	114	*
		OUTPUT THERMAL TORQUE (Nm)	4536.2	4731.3	5897.1	6822.5	*
7.5	100	INPUT MECH. POWER (KW)	69.5	71.5	96.5	140	*
		OUTPUT MECH. TORQUE (Nm)	6239.1	6418.6	8755	12827.2	*
		INPUT THERMAL POWER (KW)	50	54	85.5	130	*
		OUTPUT THERMAL TORQUE (Nm)	4488.5	4796	7757	11794.3	*
10	75	INPUT MECH. POWER (KW)	53	55	72.6	105	171.16
		OUTPUT MECH. TORQUE (Nm)	8208.8	6443.1	8689.7	12567.8	20922.6
		INPUT THERMAL POWER (KW)	45	48	65.3	86.75	137.5
		OUTPUT THERMAL TORQUE (Nm)	5271.6	5623	7816	10272.9	16808
15	50	INPUT MECH. POWER (KW)	45	48	59	85	137.5
		OUTPUT MECH. TORQUE (Nm)	7735.5	8251.2	10360.5	15260.9	25212
		INPUT THERMAL POWER (KW)	34	39	53.13	73	123.2
		OUTPUT THERMAL TORQUE (Nm)	5844.6	6704.1	9336	13106.4	22590
20	37.5	INPUT MECH. POWER (KW)	38	41.8	46.86	62	101.65
		OUTPUT MECH. TORQUE (Nm)	8612.8	9474.1	10979	14526.2	24074.8
		INPUT THERMAL POWER (KW)	27	32	42.88	58	88
		OUTPUT THERMAL TORQUE (Nm)	6119.6	7252.9	10046.5	13441.3	20841.9
25	30	INPUT MECH. POWER (KW)	30	34.1	36	57	88.35
		OUTPUT MECH. TORQUE (Nm)	8308.5	9444	10279.6	16512	25563.9
		INPUT THERMAL POWER (KW)	24	27	32	52	65
		OUTPUT THERMAL TORQUE (Nm)	6646.8	7477.6	9168	15063.5	19243.3
30	25	INPUT MECH. POWER (KW)	23	25.52	33.73	45.11	72
		OUTPUT MECH. TORQUE (Nm)	7204.5	7993.88	11341	15508.8	14027
		INPUT THERMAL POWER (KW)	21	23.13	31.25	41.25	68
		OUTPUT THERMAL TORQUE (Nm)	6578.0	7243.7	10505	14181.8	23378.4
40	18.8	INPUT MECH. POWER (KW)	20	23.76	26.5	41.8	68.53
		OUTPUT MECH. TORQUE (Nm)	8330.9	9897.1	10996.7	18897.8	30634.4
		INPUT THERMAL POWER (KW)	16	18	24	33	58
		OUTPUT THERMAL TORQUE (Nm)	6664.7	7497.8	9997	14919.3	25927.2
50	15	INPUT MECH. POWER (KW)	18	20	23.2	32	52.05
		OUTPUT MECH. TORQUE (Nm)	8938.8	9932	11225.7	17724.8	28167.7
		INPUT THERMAL POWER (KW)	15	16	21.45	22	48.75
		OUTPUT THERMAL TORQUE (Nm)	7449.0	7945.6	10105.9	12185.8	26381.9
60	12.5	INPUT MECH. POWER (KW)	14	15.73	18.8	24.2	40.6
		OUTPUT MECH. TORQUE (Nm)	8347.3	9373.8	10778.1	16085.3	26055.5
		INPUT THERMAL POWER (KW)	11	13.75	17	23	36
		OUTPUT THERMAL TORQUE (Nm)	6558.6	8193.9	9741	15287.6	23103.4
70	10.7	INPUT MECH. POWER (KW)	10	11.88	16.5	20.8	34.1
		OUTPUT MECH. TORQUE (Nm)	6693.9	7952.38	11045	14851.6	24956.7
		INPUT THERMAL POWER (KW)	8	10.45	14.8	19.5	32
		OUTPUT THERMAL TORQUE (Nm)	5355.1	7088.4	9774.9	13923.4	23419

- The Ratings are based on service factor of 1, continuously transmitted for 12 hours/day with normal overload of 100% momentarily for 15 seconds, 40% for 30 minutes, 25% for 2 hours.
- See Page No. 9 for actual service factor to nature of load and duration of operation.
- Ratios and output speeds are nominal. Exact ratios are listed on Page No. 30
- Higher rating can be obtained by using SYNTHETIC OIL, details on Page No. 32

For rating marked * consult ELECON

RATINGS AT INPUT SPEED 500 R.P.M.

GEAR RATIO	OUTPUT SPEED R.P.M.	CAPACITY	SIZE OF UNIT				
			1 $\frac{5}{8}$	1 $\frac{3}{4}$	2	2 $\frac{1}{4}$	3
5	100	INPUT POWER KW	0.72	0.86	1.4	1.52	3.46
		OUTPUT TORQUE Nm	61.9	74.3	120.3	132.1	300.7
7.5	66.7	INPUT POWER KW	0.61	0.88	0.95	1.16	3.65
		OUTPUT TORQUE Nm	81.2	85.1	114.3	144.5	388.7
10	50	INPUT POWER KW	0.47	0.5	0.85	0.98	2.6
		OUTPUT TORQUE Nm	73.3	80.2	133.1	161.6	442
15	33.3	INPUT POWER KW	0.41	0.44	0.68	0.74	1.9
		OUTPUT TORQUE Nm	85.8	102.2	156	179.2	468.6
20	25	INPUT POWER KW	0.32	0.35	0.51	0.62	1.36
		OUTPUT TORQUE Nm	89.2	107.3	156	189.5	431.2
25	20	INPUT POWER KW	0.3	0.33	0.43	0.49	1.23
		OUTPUT TORQUE Nm	100.3	113.5	173	175.5	469.9
30	16.6	INPUT POWER KW	0.27	0.3	0.36	0.42	1.15
		OUTPUT TORQUE Nm	101	117.4	175	176.4	502.8
40	12.5	INPUT POWER KW	0.23	0.27	0.33	0.37	0.93
		OUTPUT TORQUE Nm	98.4	115.5	164	192.2	525.8
50	10	INPUT POWER KW	0.19	0.21	0.25	0.3	0.85
		OUTPUT TORQUE Nm	96.8	108.3	153	180	592.6
60	8.33	INPUT POWER KW	0.17	0.19	0.21	0.25	0.7
		OUTPUT TORQUE Nm	98.8	111.1	149.2	172	561.8
70	7.14	INPUT POWER KW	0.13	0.16	0.16	0.2	0.65
		OUTPUT TORQUE Nm	88.7	106.4	124.1	155.2	599.9

GEAR RATIO	OUTPUT SPEED R.P.M.	CAPACITY	SIZE OF UNIT						
			3.54	4	5	6	7	8	9
5	100	INPUT POWER KW	6.1	7.65	12.36	16.8	24.2	31.34	40
		OUTPUT TORQUE Nm	524.3	674	1086	1476.1	2103.1	2723.6	3476.2
7.5	66.7	INPUT POWER KW	4.2	5.5	10	14.4	21.5	28.65	33
		OUTPUT TORQUE Nm	511.2	722.4	1315.8	1882.4	2792.1	3765.7	4309.1
10	50	INPUT POWER KW	3.52	4.6	8.67	12.6	6.7	23.3	28
		OUTPUT TORQUE Nm	567.4	790	1488.7	2158.7	2806	4125.4	4813.2
15	33.3	INPUT POWER KW	2.8	3.72	6	9.7	13.4	18.12	24
		OUTPUT TORQUE Nm	669.7	925.8	1507.4	2439.7	3381.8	4413.3	6125.8
20	25	INPUT POWER KW	2.2	3.1	5.2	7.55	10.5	13.3	17.5
		OUTPUT TORQUE Nm	687	1005.4	1696.4	2468.8	3425.4	4476	6009.8
25	20	INPUT POWER KW	1.75	2.5	4.6	6.6	9.4	12.1	14.5
		OUTPUT TORQUE Nm	651.8	981.3	1838.5	2644.1	3779.3	5032.4	6120.6
30	16.6	INPUT POWER KW	1.66	2	3.8	5.8	8	10.65	13
		OUTPUT TORQUE Nm	802.2	935.4	1748.9	2652.7	3649.7	5158.9	6491.7
40	12.5	INPUT POWER KW	1.35	1.6	3.1	4.8	6.8	8.67	9.78
		OUTPUT TORQUE Nm	835.4	951	1807.1	2801.7	3979.5	5067.3	6194.2
50	10	INPUT POWER KW	1.1	1.43	2.58	4	6.6	7.5	8.7
		OUTPUT TORQUE Nm	787.8	1002.4	1747	2765.7	4027.6	5386.2	6480.6
60	8.33	INPUT POWER KW	0.93	1.27	2.12	3.2	5.15	6.25	7.5
		OUTPUT TORQUE Nm	778.3	975.5	1487.5	2557.1	4097.6	5015.8	6577.8
70	7.14	INPUT POWER KW	0.8	1.1	1.8	2.85	4.14	5.55	6.6
		OUTPUT TORQUE Nm	792	978.4	1555.3	2470.2	3593.8	4973.6	6444.2

- The Ratings are based on service factor of 1, continuously transmitted for 12 hours/day with normal overload of 100% momentarily for 15 seconds, 40% for 30 minutes, 25% for 2 hours.
- See Page No. 9 for actual service factor to nature of load and duration of operation.
- Ratios and output speeds are nominal. Exact ratios are listed on Page No. 30
- Higher rating can be obtained by using SYNTHETIC OIL, details on Page No. 32

RATINGS AT INPUT SPEED 500 R.P.M.

GEAR RATIO	OUTPUT SPEED R.P.M.	CAPACITY	SIZE OF UNIT				
			10	10.5	12	14	17
5	100	INPUT MECH. POWER (KW)	75	78	102.5	122	*
		OUTPUT MECH. TORQUE (Nm)	6732.8	7002.1	9299.3	11068.5	*
		INPUT THERMAL POWER (KW)	40	46	49.2	57.5	*
		OUTPUT THERMAL TORQUE (Nm)	3590.8	4129.4	4463.7	5213.1	*
7.5	66.7	INPUT MECH. POWER (KW)	47	50.2	56.6	95	*
		OUTPUT MECH. TORQUE (Nm)	6312.1	6741.9	7617.7	12785.8	*
		INPUT THERMAL POWER (KW)	35	37.3	45.48	50.2	*
		OUTPUT THERMAL TORQUE (Nm)	4700.5	5009.4	6121.1	6756.3	*
10	50	INPUT MECH. POWER (KW)	40	43.5	51.72	70.65	130.8
		OUTPUT MECH. TORQUE (Nm)	7138.3	7762.9	9187.1	12549.6	23558.8
		INPUT THERMAL POWER (KW)	29	31.75	40	49.25	96.72
		OUTPUT THERMAL TORQUE (Nm)	5175.3	5649.8	7105.2	8748.3	17420.5
15	33.3	INPUT MECH. POWER (KW)	30	34.5	42.56	58.8	102.36
		OUTPUT MECH. TORQUE (Nm)	7880.9	9063	10985.1	15345.4	27300.6
		INPUT THERMAL POWER (KW)	24	25.7	33.45	37.31	80.6
		OUTPUT THERMAL TORQUE (Nm)	6304.7	6751.3	8633.7	9737	21497
20	25	INPUT MECH. POWER (KW)	22	26.86	35.2	45.6	91.5
		OUTPUT MECH. TORQUE (Nm)	7365.6	9029.3	11873.2	15677.3	31807.2
		INPUT THERMAL POWER (KW)	20	22.3	29.8	34.3	72.76
		OUTPUT THERMAL TORQUE (Nm)	6423.2	7496.4	10051.7	11792.3	25292.8
25	20	INPUT MECH. POWER (KW)	18	21	29	41.2	82
		OUTPUT MECH. TORQUE (Nm)	7219.8	8423.1	11922.7	17312.2	34652.2
		INPUT THERMAL POWER (KW)	15	18	24.17	30.55	64.5
		OUTPUT THERMAL TORQUE (Nm)	6016.5	7220	9937	12837.1	27257
30	16.6	INPUT MECH. POWER (KW)	16	17.35	25.6	33.83	64.37
		OUTPUT MECH. TORQUE (Nm)	7547.9	8184.8	12371.3	16737.7	32218
		INPUT THERMAL POWER (KW)	14	15.8	19	26.6	56.42
		OUTPUT THERMAL TORQUE (Nm)	6604.4	7453.6	9181.8	13160.6	28239
40	12.5	INPUT MECH. POWER (KW)	15	16	23.3	31.5	66.7
		OUTPUT MECH. TORQUE (Nm)	8938.8	9534.7	13884.9	19252.8	42805.4
		INPUT THERMAL POWER (KW)	12	13.1	17.2	20.52	47.35
		OUTPUT THERMAL TORQUE (Nm)	7151.0	7806.6	10249.8	12541.8	30387.3
50	10	INPUT MECH. POWER (KW)	14	15.4	18.6	26.6	48
		OUTPUT MECH. TORQUE (Nm)	10027.5	11030.3	13322.3	20068.4	36672
		INPUT THERMAL POWER (KW)	10	12	14.16	17.35	37.27
		OUTPUT THERMAL TORQUE (Nm)	7162.5	8595	10142.1	13086.7	28474.3
60	8.33	INPUT MECH. POWER (KW)	10	12.83	15.7	20.7	38
		OUTPUT MECH. TORQUE (Nm)	8254.5	10590.5	13139.6	18036.1	33981
		INPUT THERMAL POWER (KW)	8.5	10.25	12.5	15.6	33.25
		OUTPUT THERMAL TORQUE (Nm)	7016.3	8460.9	10461.4	13532.4	29733.4
70	7.14	INPUT MECH. POWER (KW)	8.8	10.2	14.36	16.12	30
		OUTPUT MECH. TORQUE (Nm)	8592.3	9959.3	13962.5	16170.8	30495.8
		INPUT THERMAL POWER (KW)	6.9	8.6	11.5	14.2	28.7
		OUTPUT THERMAL TORQUE (Nm)	6737.2	8397	11228.6	14244.8	29174.3

- The Ratings are based on service factor of 1, continuously transmitted for 12 hours/day with normal overload of 100% momentarily for 15 seconds, 40% for 30 minutes, 25% for 2 hours.
- See Page No. 9 for actual service factor to nature of load and duration of operation.
- Ratios and output speeds are nominal. Exact ratios are listed on Page No. 30
- Higher rating can be obtained by using SYNTHETIC OIL, details on Page No. 32

For rating marked * consult ELECON

1 5/8 SNU

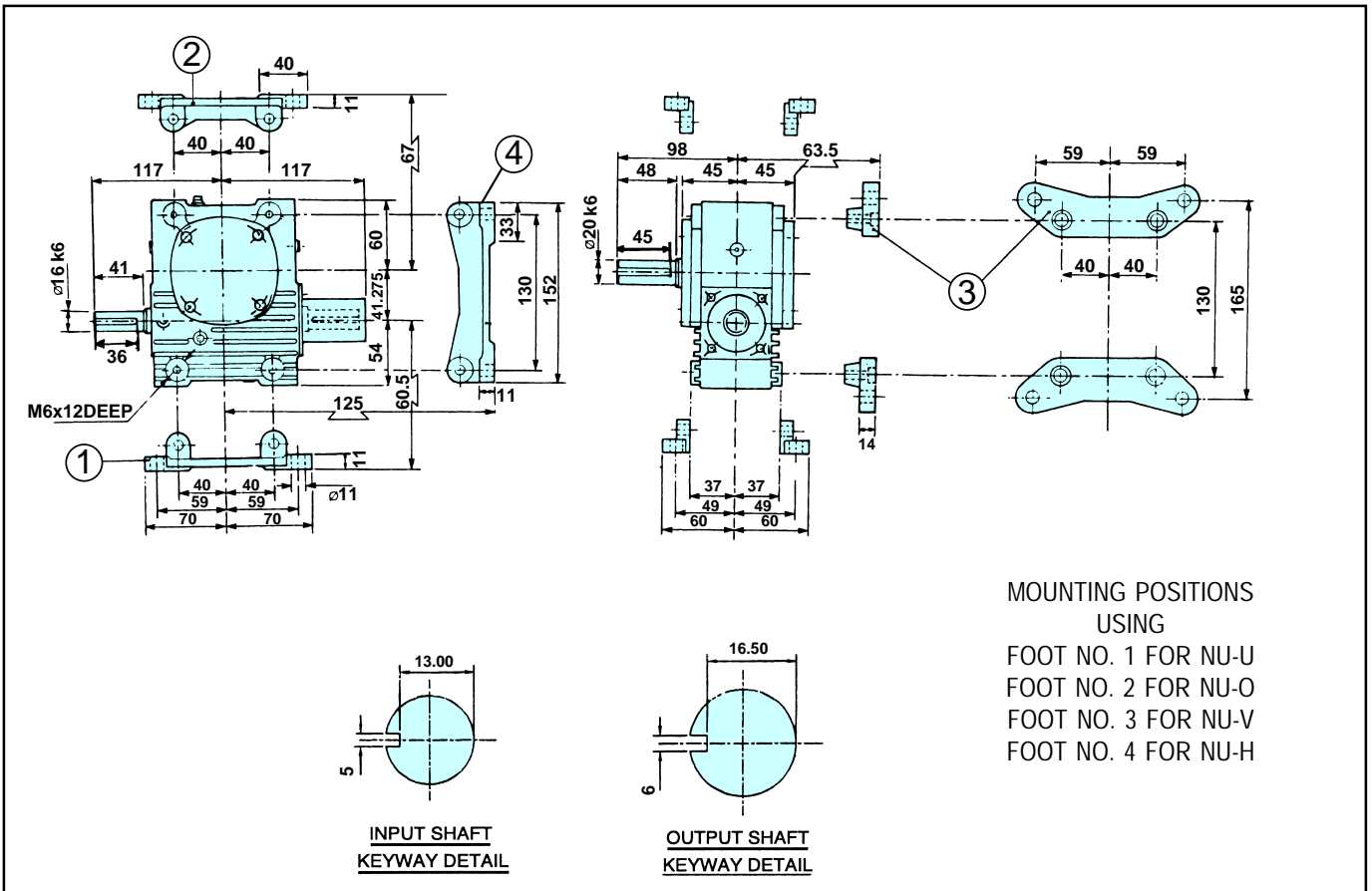

1 3/4 SNU

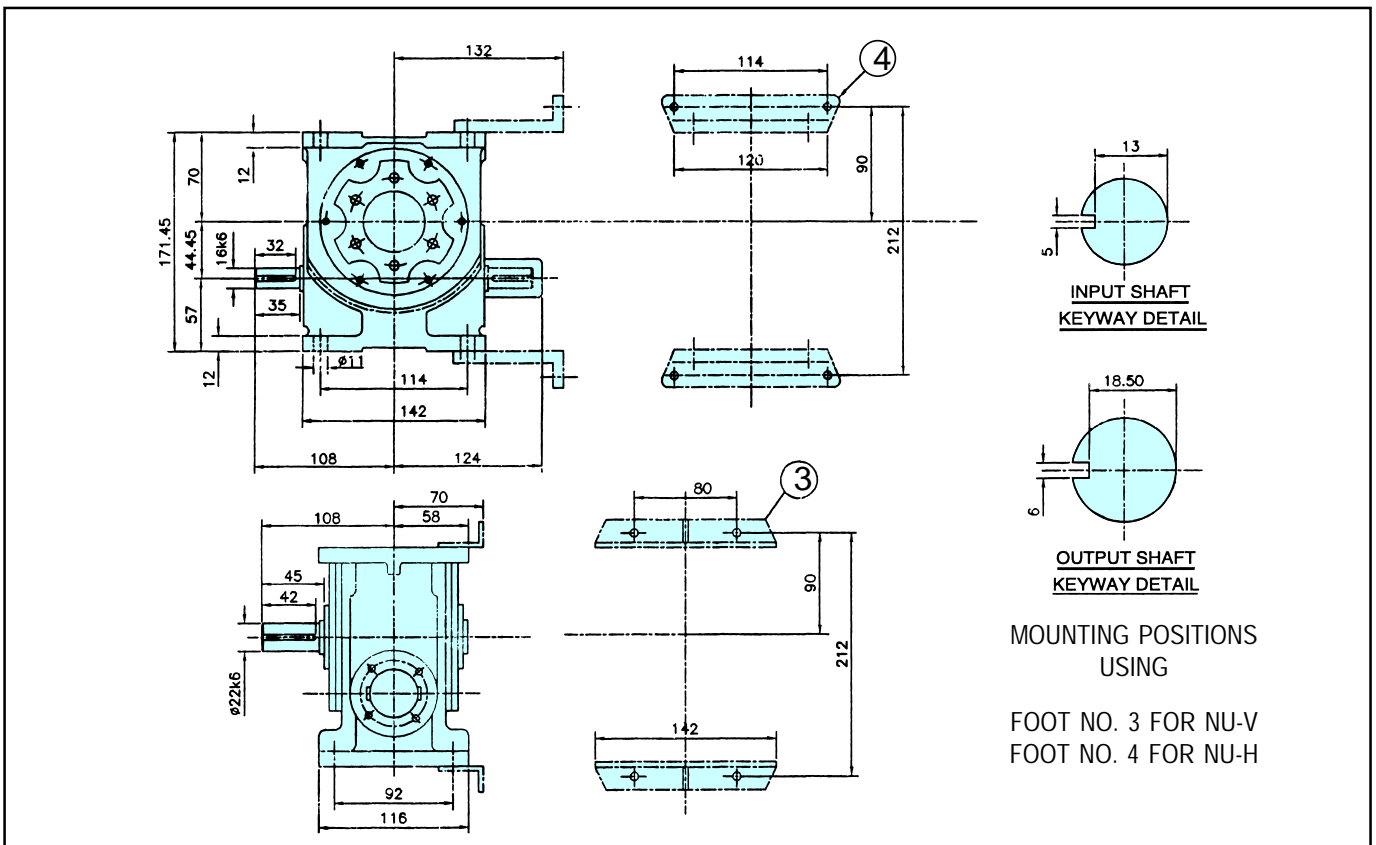

Key & Keyways as per IS 2048. Shaft limits up to 58dia.-k6 and above 58 dia.-m6

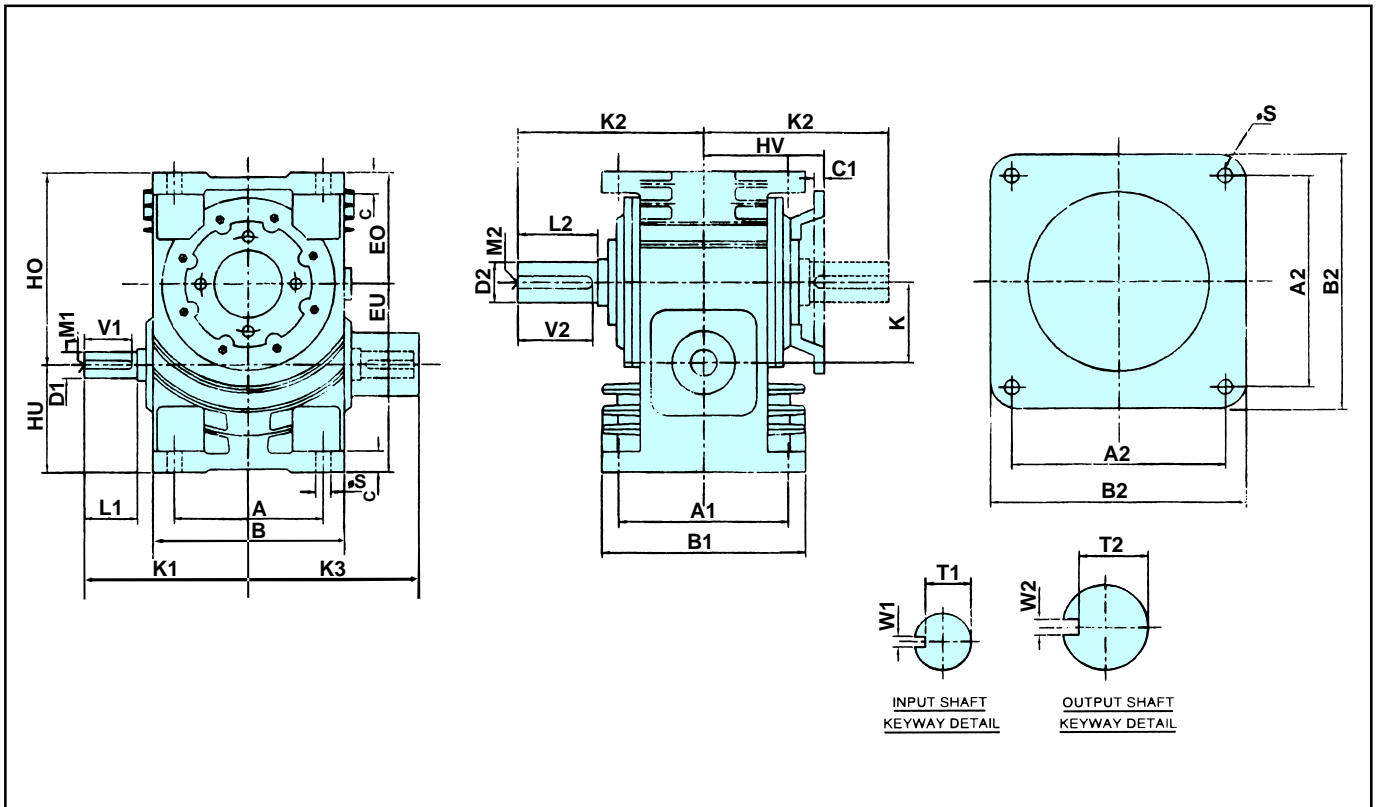

SIZE	A	B	A1	B1	C	A2	B2	C1	F S	HU	EU	HO	EO	HV	K	K1	K2	K3	D1	L1	M1	T1	W1	D2	L2	M2	T2	W2	V1	V2
2 SNU	95	142	100	125	14	120	150	14	11	70	120.8	133.8	83	94	50.8	133	128	140	16	47	-	13	5	25	57	-	21	8	45	55
2 1/4 SNU	105	152	105	132	14	120	150	14	11	70	127.15	142.15	85	100	57.15	142	136	150	22	50	-	18.5	6	25	60	-	21	8	45	55
3 SNU	140	180	160	192	20	200	240	16	14	102	178.20	181.20	105	125	76.20	155	175	165	25	50	MB	21	8	38	75	M12	33	10	45	70

3.54 SNU-U

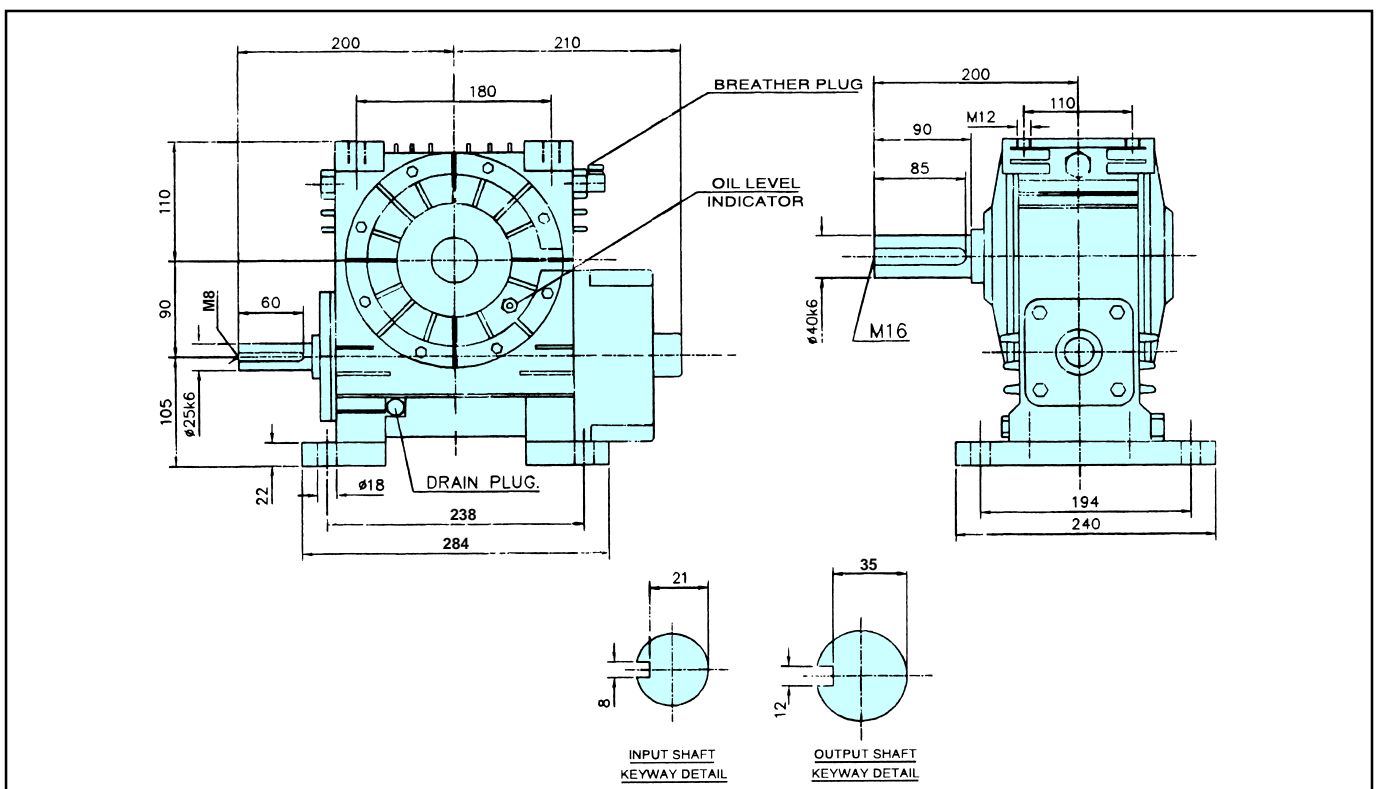

Key & Keyways as per IS 2048. Shaft limits up to 58dia.-k6 and above 58 dia.-m6

3.54 SNU-O

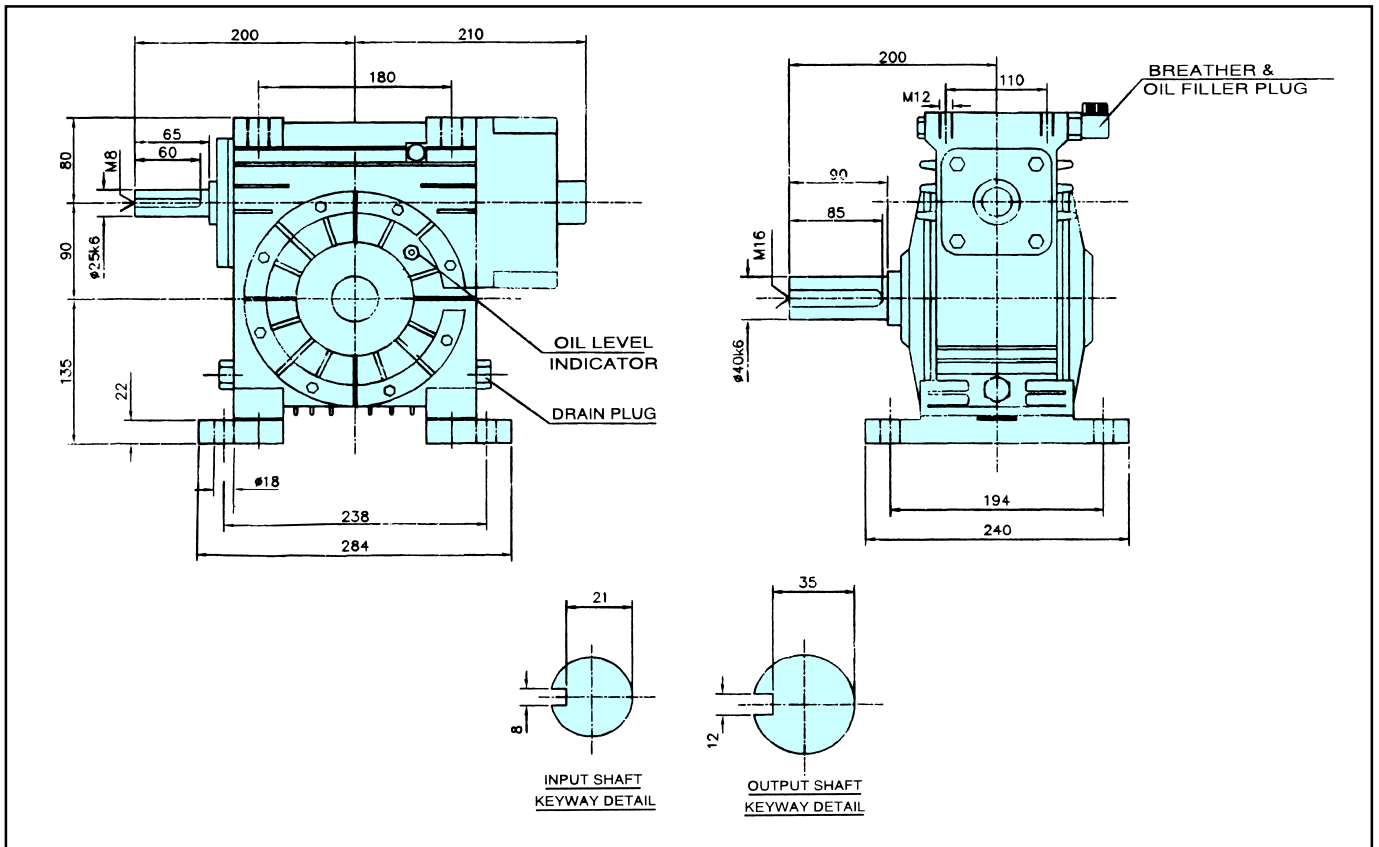

3.54 SNU-V

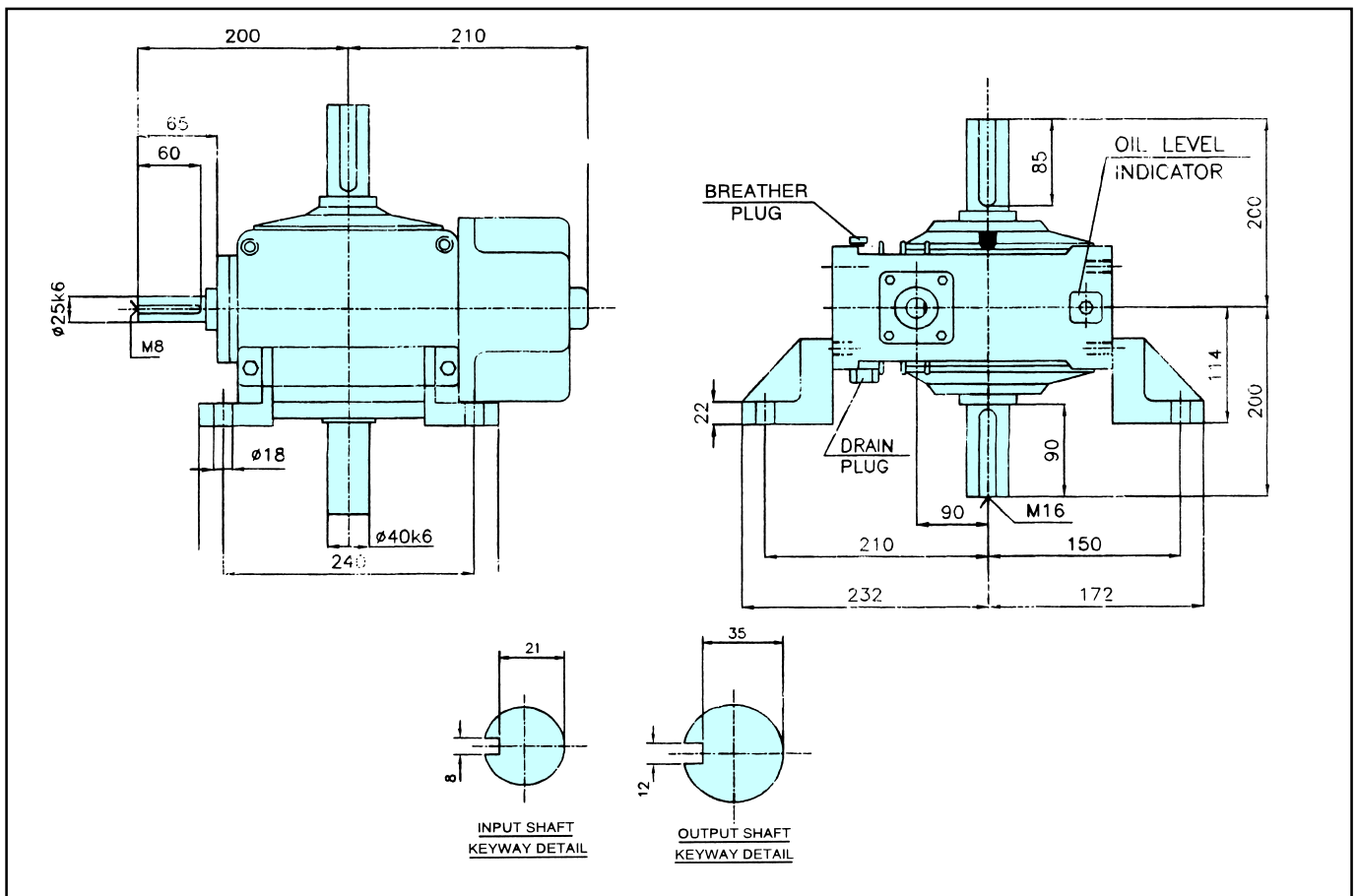

Key & Keyways as per IS 2048. Shaft limits up to 58dia.-k6 and above 58 dia.-m6

SNU-U

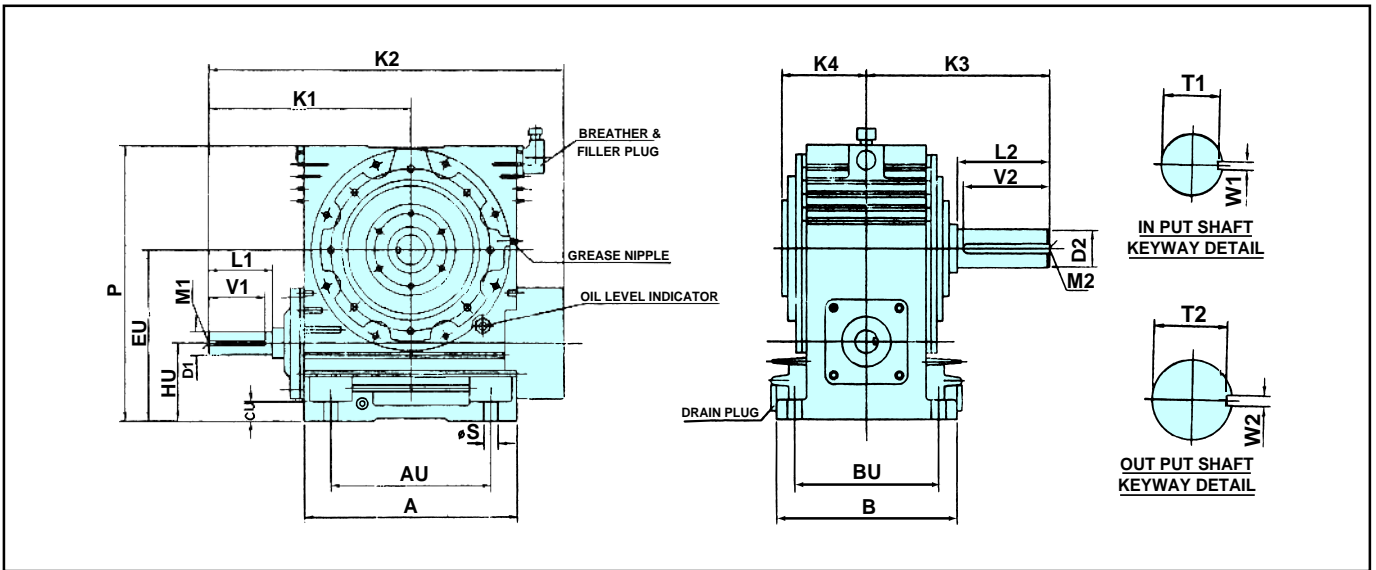

SIZE	A	AU	B	BU	CU	S	HU	EU	P	D1	L1	V1	M1	T1	W1	K1	K2	D2	L2	V2	M2	T2	W2	K3	K4
4 SNU-U	250	180	200	160	25	18	108	209.6	325	32	65	60	M12	27	10	215	440	45	90	85	M16	39.5	14	215	115
5 SNU-U	300	220	252	200	30	18	118	245	385	35	70	65	M12	30	10	242	492	50	100	95	M16	44.5	14	235	130
6 SNU-U	354	266	302	241	32	23	127	279.4	450	38	75	70	M12	33	10	279	580	58	114	111	M20	52	16	274	155
7 SNU-U	400	306	340	265	36	23	146	323.8	524	40	82	79	M16	35	12	311	656	65	130	127	M20	58	18	287	160
8 SNU-U	440	343	340	265	40	27	146	349.2	574	45	88	85	M16	39.5	14	342	710	70	140	137	M20	62.5	20	312	175
9 SNU-U	490	390	344	282	40	27	154	382.6	635	50	95	92	M16	44.5	14	375	776	75	145	140	M20	67.5	20	325	180
10.5 SNU-U	590	432	430	330	50	33	172	438.7	720	60	115	110	M20	53	18	450	925	80	150	147	M20	71	22	352	200

SNU-O

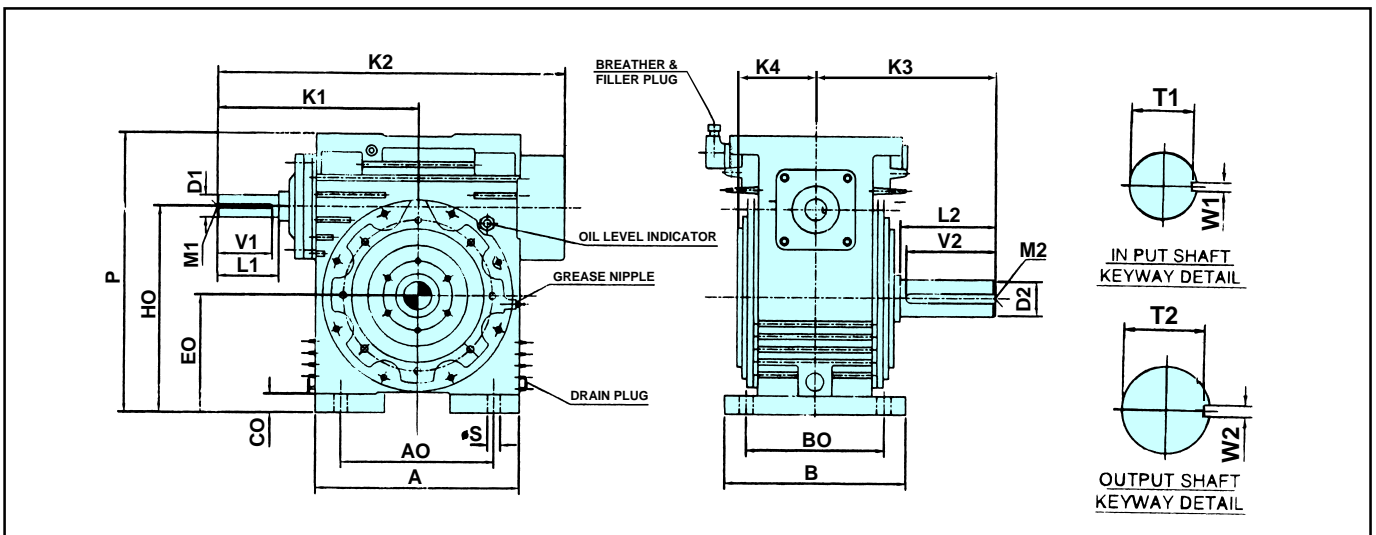

SIZE	A	AO	B	BO	CO	S	HO	EO	P	D1	L1	V1	M1	T1	W1	K1	K2	D2	L2	V2	M2	T2	W2	K3	k4
4 SNU-O	250	180	240	200	25	18	241.6	140	350	32	65	60	M12	27	10	215	440	45	90	85	M16	39.5	14	215	115
5 SNU-O	300	220	270	230	25	18	292	165	410	35	70	65	M12	30	10	242	492	50	100	95	M16	44.5	14	235	130
6 SNU-O	354	266	310	250	30	23	352.4	200	479.4	38	75	70	M12	33	10	279	580	58	114	111	M20	52	16	274	155
7 SNU-O	400	306	340	266	44	23	421.8	244	568	40	82	79	M16	35	12	311	656	65	130	127	M20	58	18	287	160
8 SNU-O	440	343	340	266	44	27	472.2	269	618	45	88	85	M16	39.5	14	342	656	70	140	137	M20	62.5	20	312	175
9 SNU-O	490	390	414	340	44	27	524.6	296	679	50	95	92	M16	44.5	14	375	776	75	145	140	M20	67.5	20	325	180
10.5 SNU-O	590	432	484	400	50	33	597.7	331	770	60	115	110	M20	53	18	450	925	80	150	147	M20	71	22	352	200

Key & Keyways as per IS 2048. Shaft limits up to 58dia.-k6 and above 58 dia.-m6

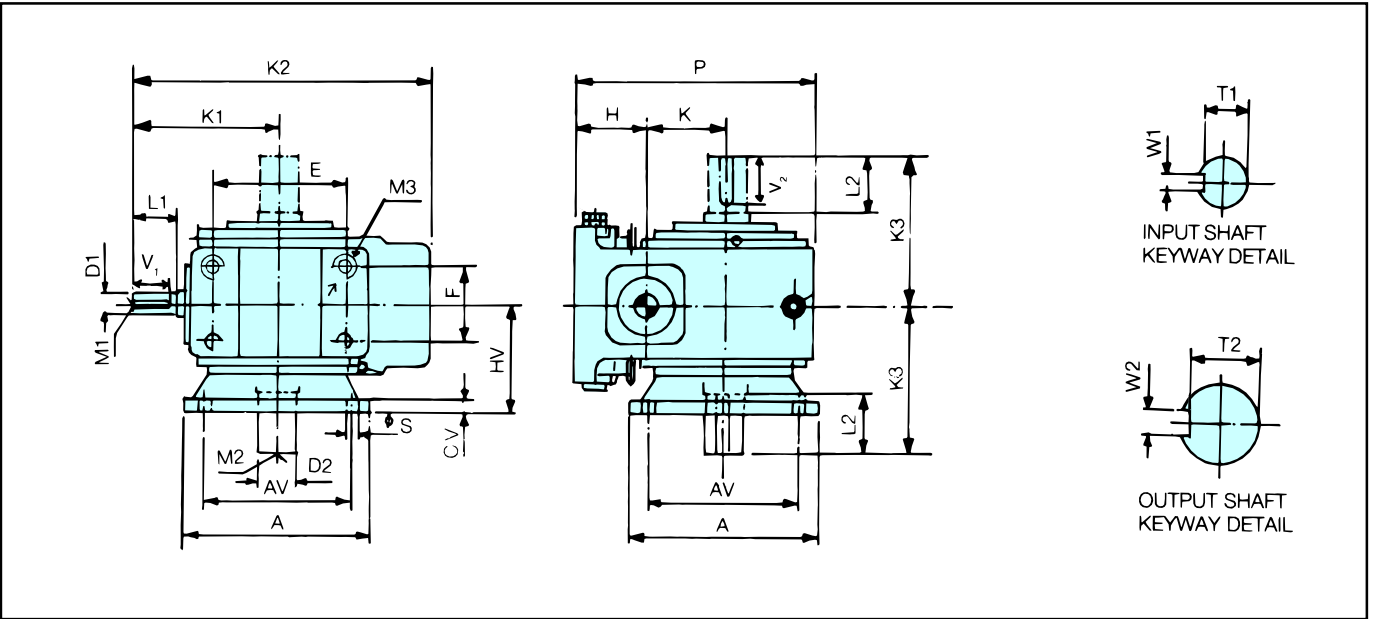

Size	A	AV	CV	S	HV	H	K	P	D1	L1	V1	M1	T1	W1	K1	K2	D2	L2	V2	M2	T2	W2	K3	E	F	M3
4 SNU-V	280	235	20	18	140	108	101.6	325	32	65	60	M12	27	10	215	440	45	90	85	M16	39.5	14	215	200	100	M16
5 SNU-V	320	260	22	18	185	118	127	385	35	70	65	M12	30	10	242	492	50	100	95	M16	44.5	14	235	240	130	M16
6 SNU-V	340	270	25	23	180	127	152.4	450	38	75	70	M12	33	10	279	580	58	114	111	M20	52	16	274	280	150	M20
7 SNU-V	400	320	40	27	200	146	177.8	524	40	82	79	M16	35	12	311	656	65	130	127	M20	58	18	287	320	150	M20
8 SNU-V	440	360	40	27	220	146	203.2	574	45	88	85	M16	39.5	14	342	710	70	140	137	M20	62.5	18	312	340	180	M24
9 SNU-V	490	410	40	27	240	154	228.6	635	50	95	92	M16	44.5	14	375	776	75	145	140	M20	67.5	20	325	386	180	M24
10.5 SNU-V	560	480	40	33	260	172	266.7	720	60	115	110	M20	53	18	450	925	80	150	147	M20	71	22	352	440	220	M30

SNU-SM SHAFT MOUNTED WORM GEAR UNIT

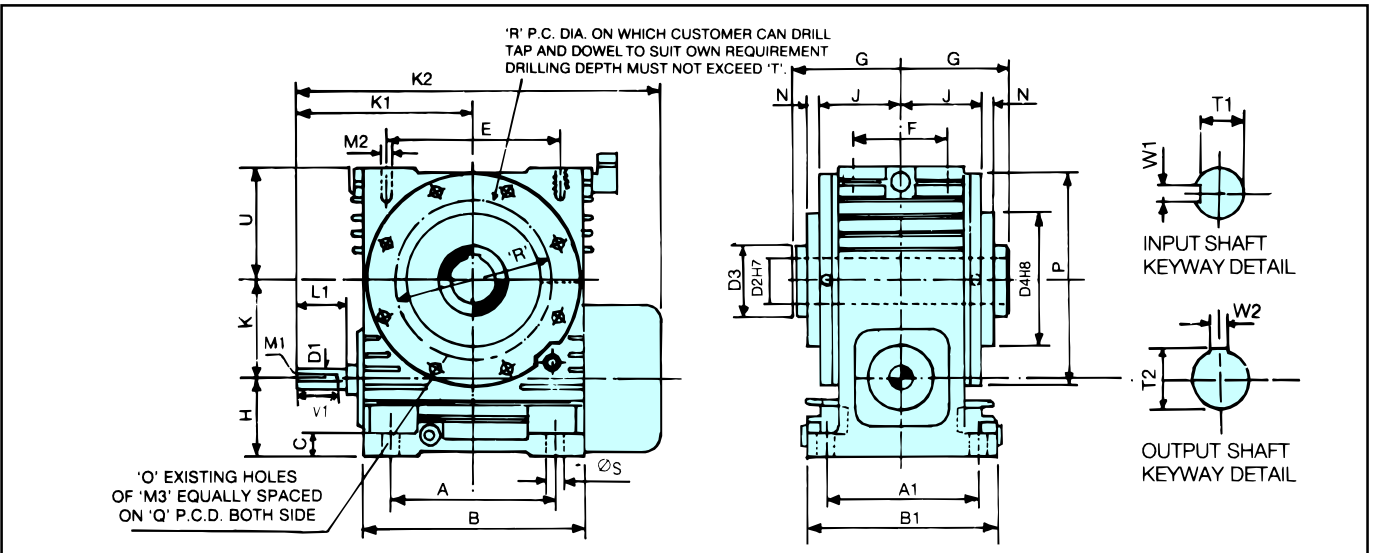

SIZE	K	H	U	K1	K2	G	J	N	D1	L1	V1	M1	T1	W1	D2	T2	W2	D3	D4	P	A	A1	B	B1	C	S	E	F	M2	O	Q	M3	R	T
2 1/4 SNU-SM	57.15	70	85	142	295	75	58	4	22	50	45	-	18.5	8	30	33.3	8	50	105	135	105	105	152	132	14	11	105	105	11	8	124	M8	-	-
3 SNU-SM	76.2	102	105	155	330	100	80	5	25	50	45	M8	21	8	50	53.8	14	80	138	177	140	160	180	192	20	14	140	160	14	8	158	M8	-	-
4 SNU-SM	101.6	108	115	215	440	115	95	6	32	65	60	M12	27	10	65	69.4	18	95	146	222	180	160	250	200	25	18	200	100	M16	8	200	M8	165	20
5 SNU-SM	127	118	140	242	492	145	115	15	35	70	65	M12	30	10	70	75.1	20	105	195	272	220	200	300	252	30	18	240	130	M16	8	250	M10	210	20
6 SNU-SM	152.4	127	170	279	580	165	132	20	38	75	70	M12	33	10	75	80.1	20	105	205	330	266	241	354	302	32	23	280	150	M20	8	305	M10	250	20
7 SNU-SM	177.8	146	200	311	656	160	132	8	40	82	79	M16	35	12	80	85.6	22	120	222	390	306	266	400	340	36	23	320	150	M20	12	355	M10	280	20
8 SNU-SM	203.2	146	225	342	710	180	148	8	45	88	85	M16	39.5	14	90	95.6	25	130	263	445	343	266	440	340	40	27	340	160	M24	12	405	M12	318	20
9 SNU-SM	228.6	154	252.4	375	776	190	157	8	50	95	92	M16	44.5	14	95	100.6	25	140	266	492	390	282	490	344	40	27	386	180	M24	12	460	M12	330	20
10.5 SNU-SM	266.7	172	281.3	450	925	205	180	8	60	115	110	M20	53	18	100	106.6	28	152	292	540	432	330	590	430	50	33	440	220	M30	12	510	M12	380	20

Key & Keyways as per IS 2048. Shaft limits up to 58dia.-k6 and above 58 dia.-m6

These models are easily adaptable for various types of mountings such as underdriven, overdriven or vertical where avoids the mounting requirement of prime mover.

The flange mounting type motors of various rpm are adaptable to the worm reducer with adaptor housing. The solid motor shaft is coupled with hollow worm shaft by means of key, (1 3/4 and 2 1/4 size) and incase 3 and 4 size coupling is provided where it allows easier removal of the motor for maintenance, if any. Which leads to advantages (a) Comprehensive maintenance of inhouse stock and in turn faster delivery (b). Quick interchangeability of handing as well from underdriven to overdriven.

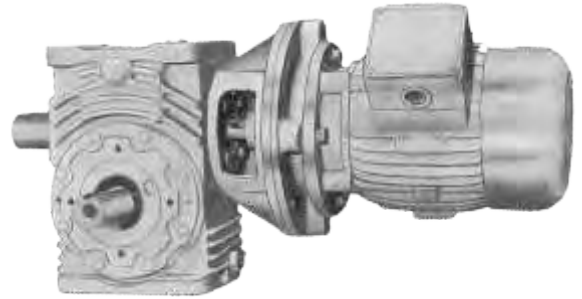

1 3/4 SWM-U-71

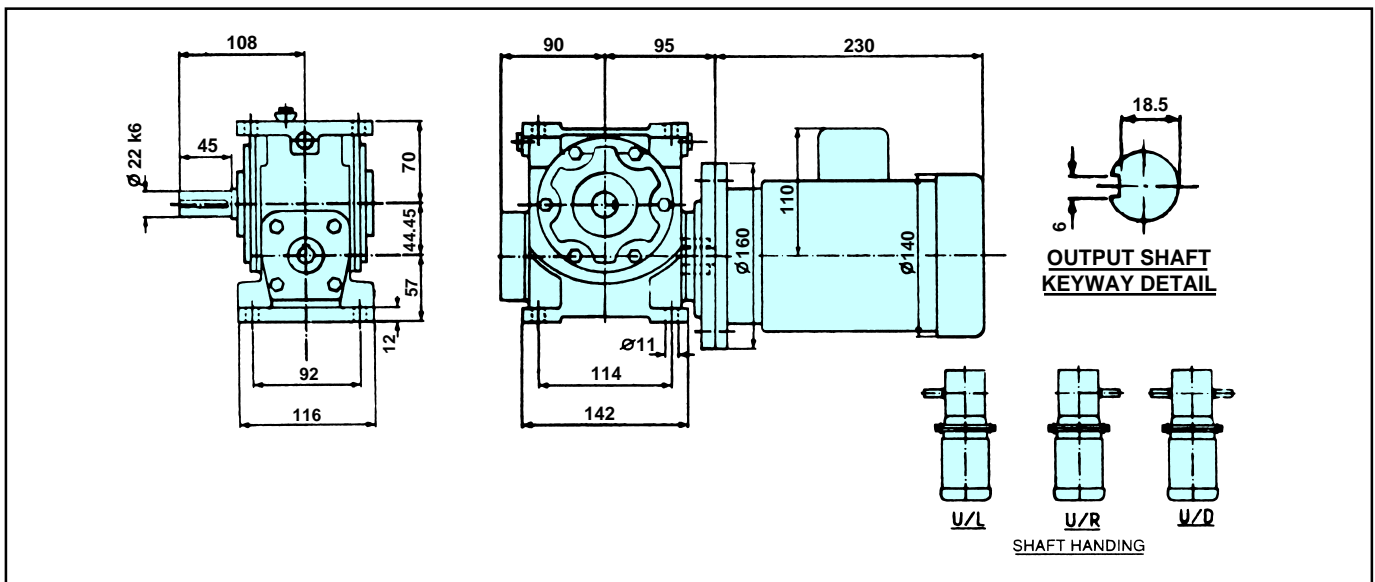

1 3/4 SWM-O-71

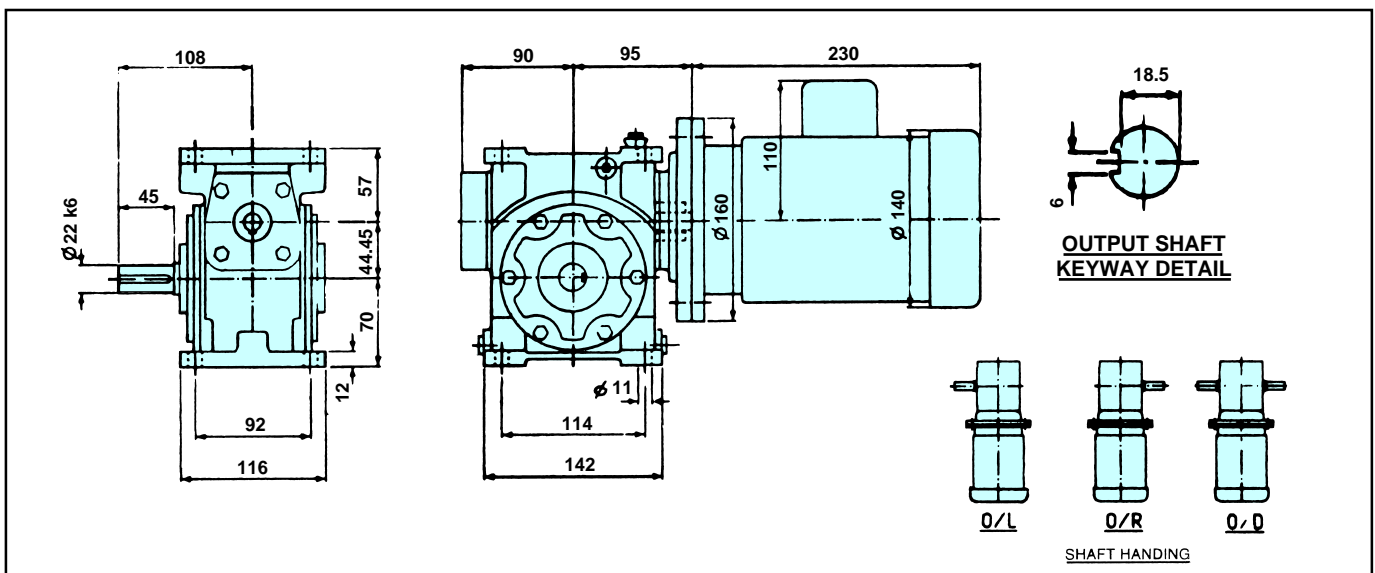

Key & Keyways as per IS 2048. Shaft limits up to 58dia.-k6 and above 58 dia.-m6

2 1/4 SWM-U-80

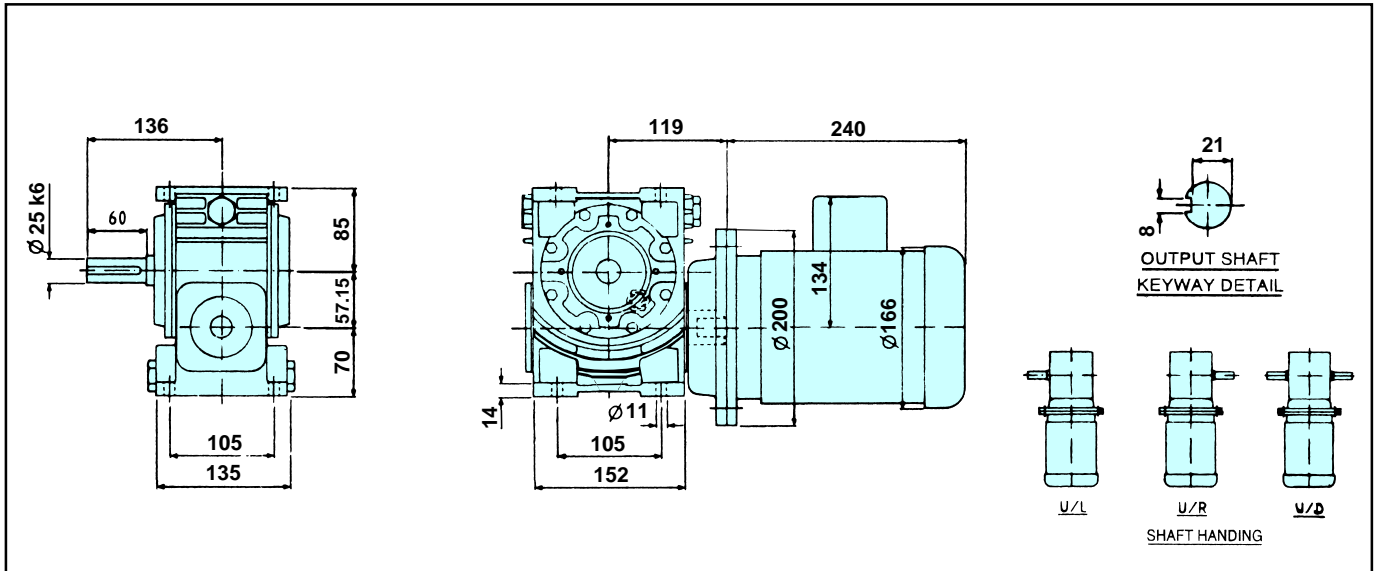

2 1/4 SWM-O-80

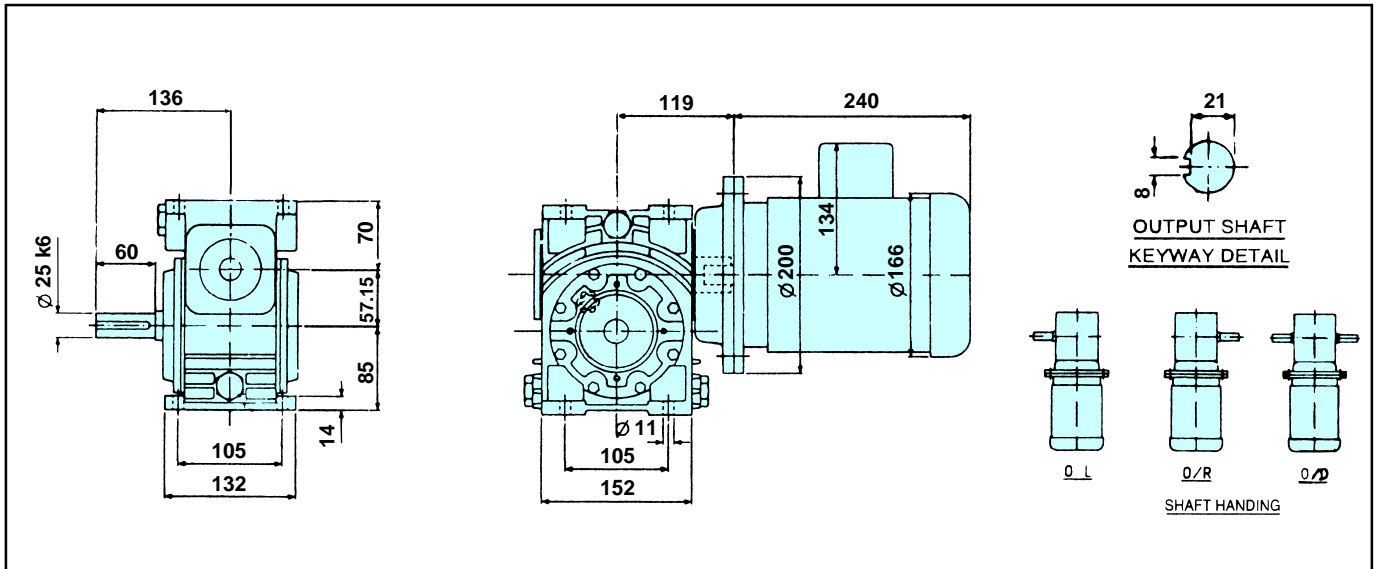

3 SWM-U

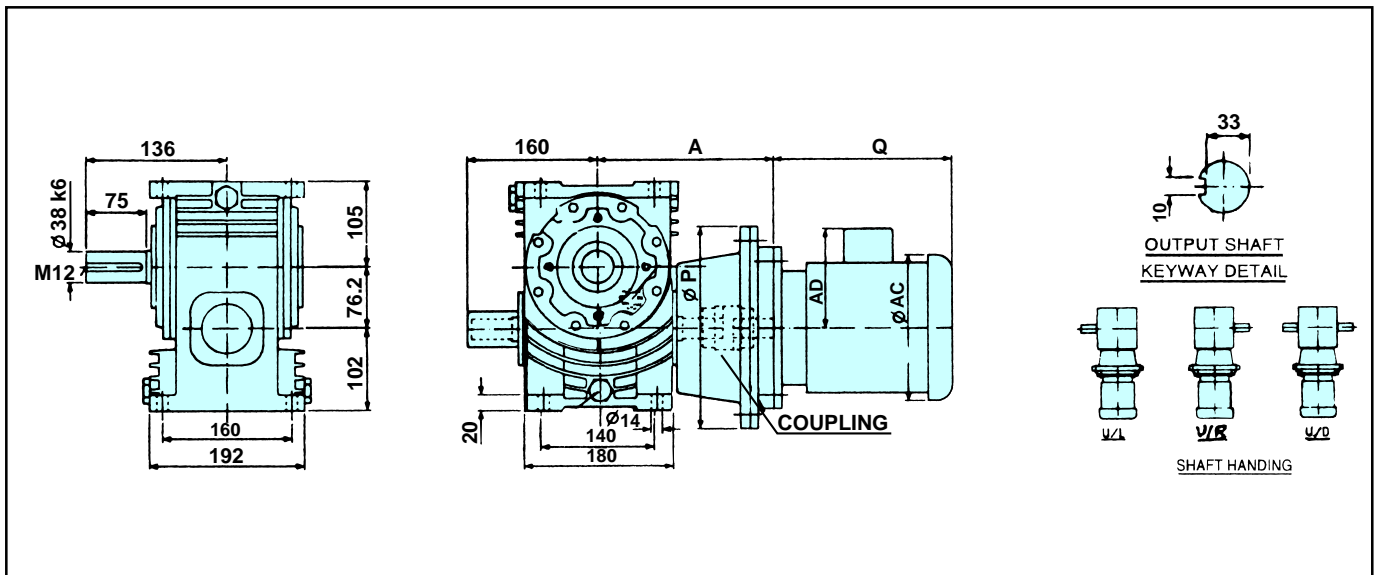

Key & Keyways as per IS 2048. Shaft limits upto 58dia.-k6 and above 58 dia.-m6

3 SWM-O

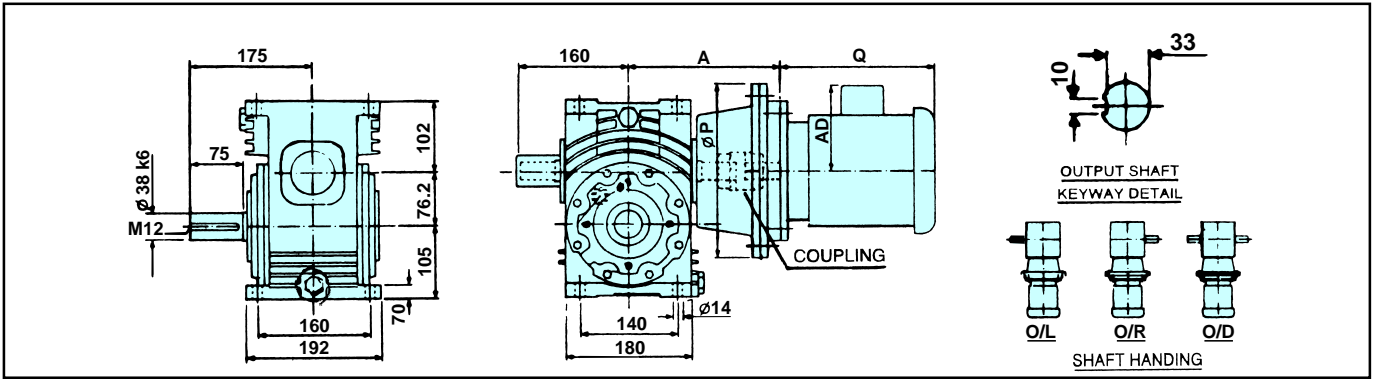

GEAR SIZE	MOTOR FRAME SIZE	MOTOR KW @			DIMENSIONS					GEAR SIZE
		1500	1000	750	A	P	Q	AC	AD	
3 SWM-U-80K	80-K	0.55	0.37	0.20	208	250	230	156	122	3 SWM-O-80K
3 SWM-U-80N	80-N	0.75	0.55	0.25	280	250	230	156	122	3 SWM-O-80N
3 SWM-U-90S	90-S	1.10	0.75	0.37	218	250	240	476	133	3 SWM-O-90S
3 SWM-U-90L	90-L	1.50	1.10	0.55	218	250	265	176	133	3 SWM-O-90L
3 SWM-U-100L	100-L	2.20	1.50	1.10	228	250	298	212	146	3 SWM-O-100L
3 SWM-U-112S	112-S	3.70	2.20	1.50	228	250	318	234	170	3 SWM-O-112S

4 SWM-U

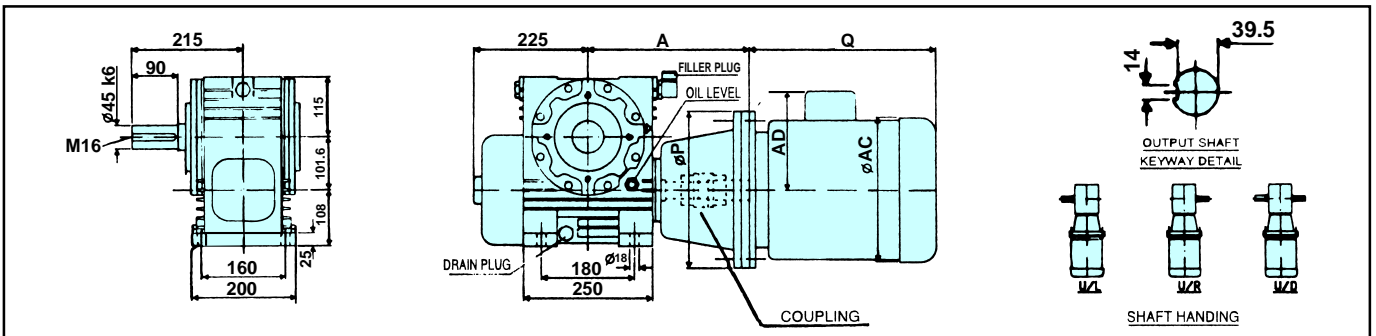

4 SWM-O

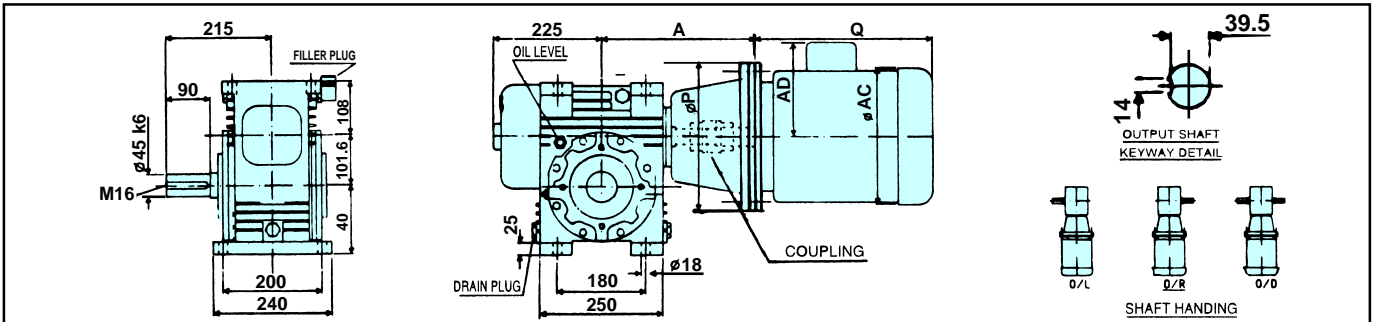

GEAR SIZE	MOTOR FRAME SIZE	MOTOR KW @			DIMENSIONS					GEAR SIZE
		1500	1000	750	A	P	Q	AC	AD	
4 SWM-U-80K	80-K	0.55	0.37	0.20	273	250	230	156	122	4 SWM-O-80K
4 SWM-U-80N	80-N	0.75	0.55	0.25	273	250	230	156	122	4 SWM-O-80N
4 SWM-U-90S	90-S	1.10	0.75	0.37	283	250	240	176	133	4 SWM-O-90S
4 SWM-U-90L	90-L	1.50	1.10	0.55	283	250	265	176	133	4 SWM-O-90L
4 SWM-U-100L	100-L	2.20	1.50	1.10	293	250	298	212	146	4 SWM-O-100L
4 SWM-U-112M	112-M	3.70	2.20	1.50	293	250	318	234	170	4 SWM-O-112M
4 SWM-U-132S	132-S	5.50	3.70	2.20	313	300	360	274	189	4 SWM-O-132S
4 SWM-U-132M	132-M	7.50	5.50	3.00	313	300	398	274	189	4 SWM-O-132M
4 SWM-U-160M	160-M	11.00	7.50	5.50	347	350	472	335	233	4 SWM-O-160M

Dimensions 'AC' and 'Q' are Subject to change as per motor make. Key & Keyways as per IS 2048. Shaft limits up to 58dia.-k6 and above 58 dia.-m6

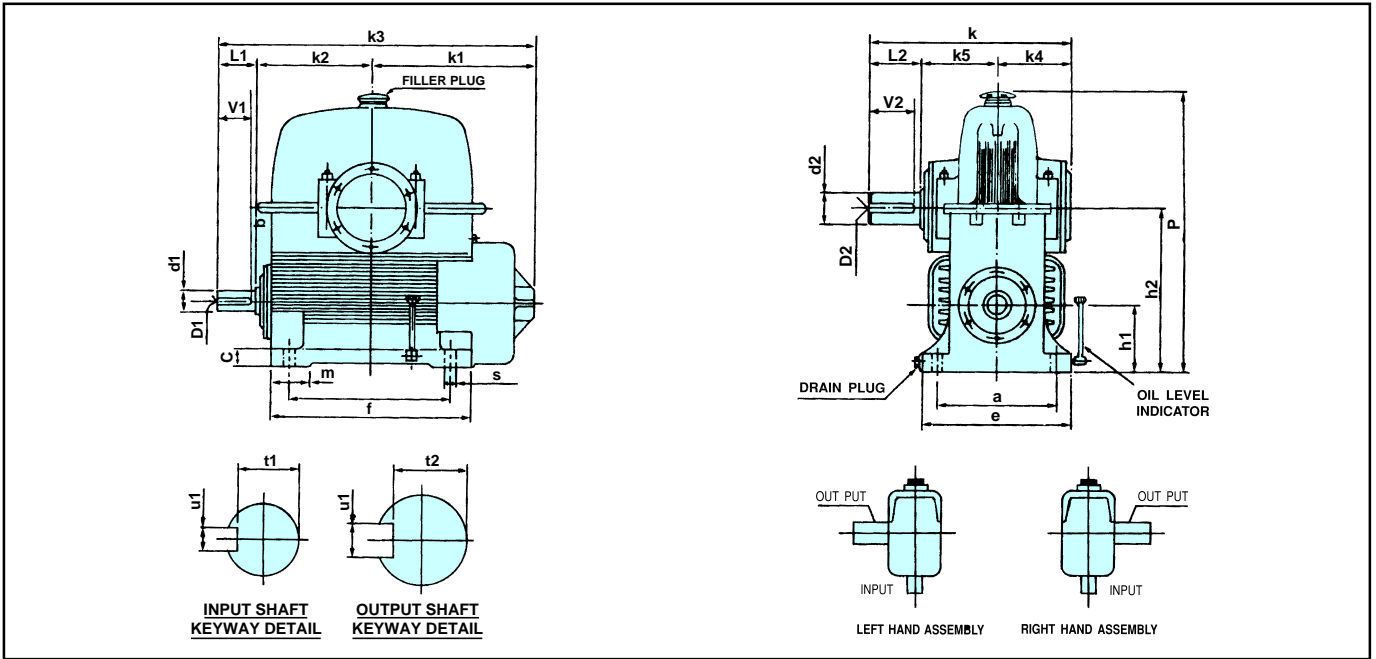

SIZE	GEARBOX MOUNTING DETAIL							CLEARANCE DIMENSIONS									SHAFT END DETAILS											
	a	b	c	e	f	m	s	h1	h2	k	k1	k2	k3	k4	k5	P	d1	L1	V1	t1	u1	D1	d2	L2	V2	t2	u2	D2
12 SFU	368	521	55	540	690	150	33	190.5	495.3	589	505	360	990	208	216	860	60	125	120	53	18	M20	85	165	160	76	22	M20
14 SFU	432	597	65	560	820	180	33	216	571.6	635	545	450	1135	215	220	970	80	140	135	71	22	M20	110	200	195	100	28	M24
17 SFU	508	762	75	600	920	170	33	254	685.8	825	650	520	1340	300	310	1185	85	170	160	78	22	M20	135	215	210	123	36	M30

SFO

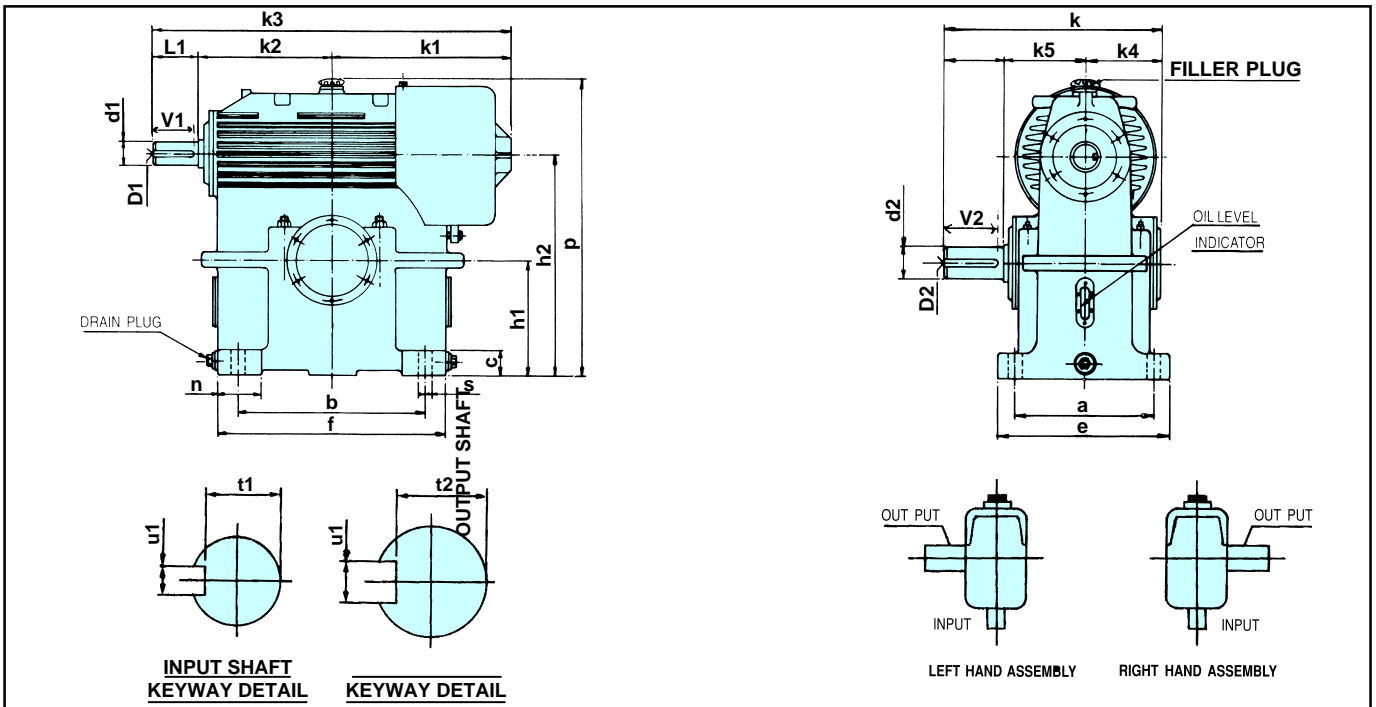

SIZE	GEARBOX MOUNTING DETAIL							CLEARANCE DIMENSIONS									SHAFT END DETAILS											
	a	b	c	e	f	m	s	h1	h2	k	k1	k2	k3	k4	k5	P	d1	L1	V1	t1	u1	D1	d2	L2	V2	t2	u2	D2
12 SFO	440	530	55	540	630	125	33	330	634.8	589	500	360	985	208	216	819	60	125	120	53	18	M20	85	165	160	76	22	M20
14 SFO	470	620	65	560	770	150	33	395	750.6	738	610	450	1200	258	280	952	80	140	135	71	22	M20	110	200	195	100	28	M24
17 SFO	510	750	75	600	920	170	33	460	891.8	825	650	520	1340	300	310	1146	85	170	160	76	22	M20	135	215	210	123	36	M30

Key & Keyways as per IS 2048. Shaft limits upto 58dia.-k6 and above 58 dia.-m6

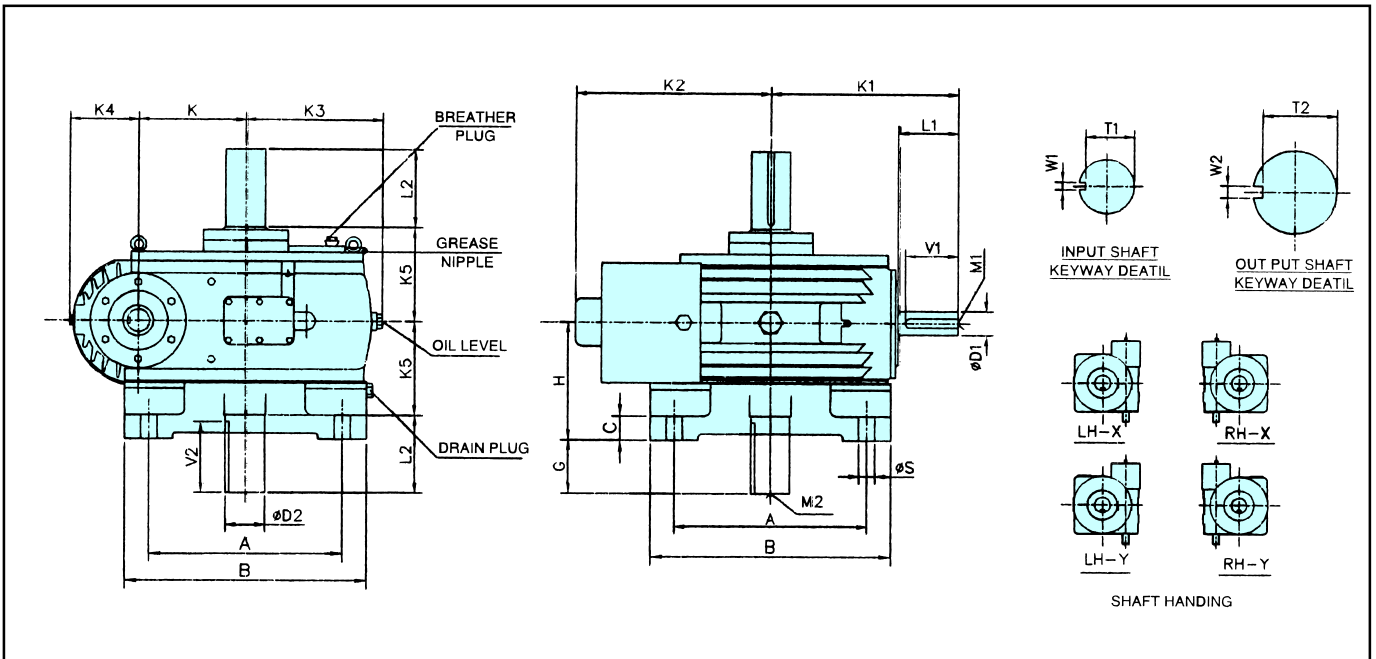

SIZE	A	B	C	S	H	K1	K2	K3	K	K4	K5	G	D1	L1	V1	T1	W1	M1	D2	L2	V2	T2	W2	M2
12 SFV	500	620	60	33	280	485	500	350	304.8	175	216	101	60	125	120	53	18	M20	85	165	160	76	22	M20
14 SFV	580	700	65	33	300	590	545	419	355.6	200	220	120	80	140	135	71	22	M20	110	200	195	100	28	M24
17 SFV	800	1000	75	40	345	690	651	520	431.8	238	310	180	85	170	160	76	22	M20	135	215	210	123	36	M30

SSM

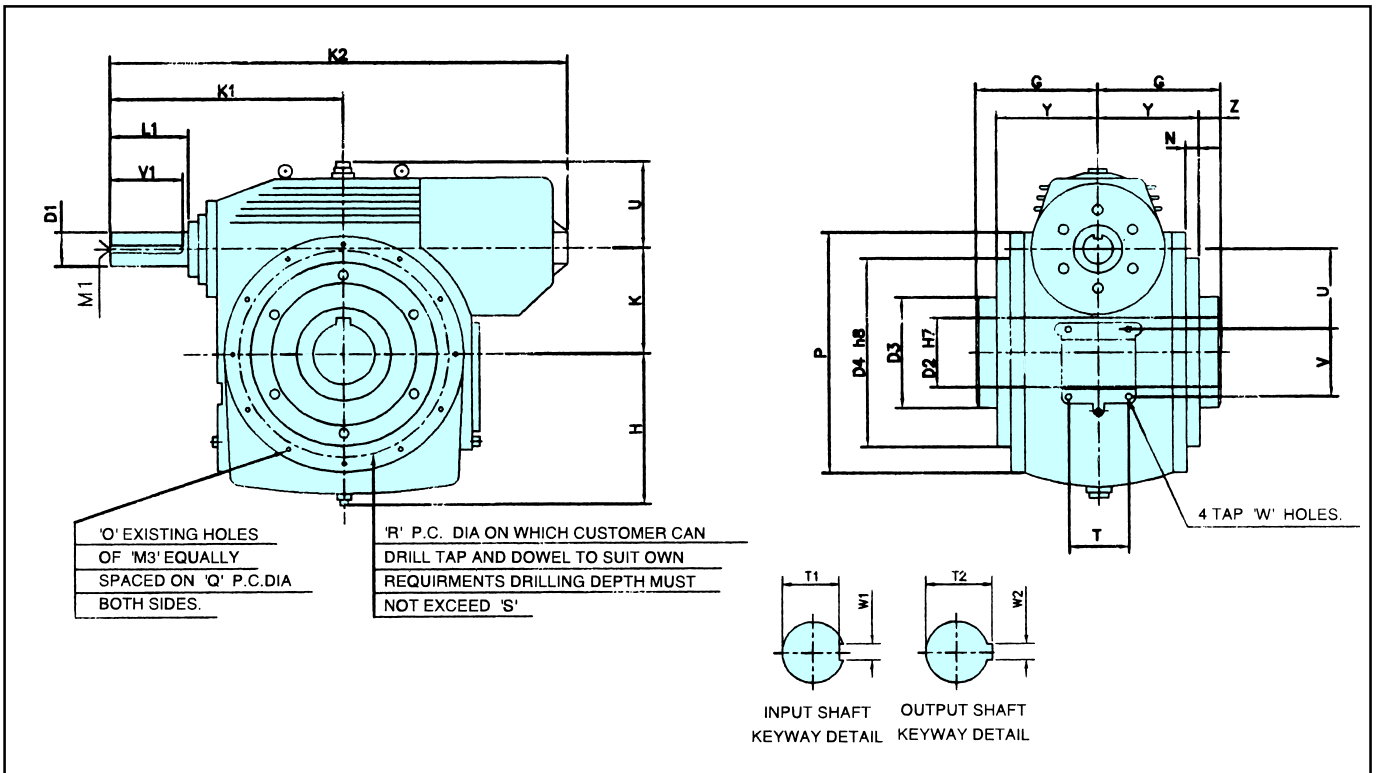

SIZE	K	H	U	K1	K2	D1	L1	V1	M1	T1	W1	D2	T2	W2	D3	D4	P	G	N	Y	Z	O	Q	M3	R	S	T	U	V	W
12 SSM	304.8	380	226	485	990	60	125	120	M20	53	18	110	116.4	28	180	360	640	220	10	200	20	12	605	M12	450	25	140	225	175	M24
14 SSM	355.6	450	250	590	1180	80	140	135	M20	71	22	140	148.4	36	185	400	770	240	10	225	15	12	720	M16	530	25	140	226	235	M24

Key & Keyways as per IS 2048. Shaft limits upto 58dia.-k6 and above 58 dia.-m6

ACTUAL GEAR RATIO

SIZE OF UNIT	NOMINAL RATIO										
	5	7.5	10	15	20	25	30	40	50	60	70
1 5/8	5.25	7.33	10.5	14.5	20	25	30	40	50	60	70
1 3/4	5.20	7.33	9.66	14.5	21	26	29	40	50	60	70
2	5	7.5	9.5	15	19	25	30	40	50	61	70
2 1/4	4.8	7	10.5	14.5	21	24	29	39	50	60	70
3	4.83	7.25	9.67	14.5	20	25	30	40	50	60	70
3.54	4.83	7.25	9.66	14.5	20	25	30	40	50	59	70
4	4.83	7.24	9.67	14.5	19.5	25	30	40	50	60	71
5	4.83	7.25	9.67	14.5	19.5	25	30	40	50	60	71
6	4.86	7.25	9.67	14.5	19.5	25	30	40	50	60	70
7	5.14	7.25	9.67	14.67	19.5	24.5	30	40	50	60	71
8	5.14	7.20	9.75	14.67	19.5	24.5	30	40	50	60	71
9	5.14	7.20	9.75	14.67	19.5	24.5	30	40	50	60	71
10	4.74	7.17	9.5	14.33	19.5	24.5	29.5	40	50	60	70
10.5	5.14	7.33	9.75	14.67	19.5	24.5	29.5	40	50	60	70
12	4.9	7.43	9.8	14.67	20.5	24.5	29.5	40	50	60	70
14	5.1	7.57	9.8	14.67	20.33	24.5	30.5	39	49	61	69
17	5.1	7.37	9.83	14.75	19.66	25.5	29.5	40	49	60	71

OVERHUNG LOADS :

Whenever a sprocket, gear, sheave or pulley is mounted on the output shaft, a calculation should be made to determine the overhung load in Newtons on the shaft, using the formula :

$$P = \frac{KW \times 9550 \times K}{N \times R}$$

Where, P = equivalent overhung load in Newtons
 KW = power carried by shaft in Kilo Watts
 N = r.p.m. of the shaft
 R = pitch radius of sprocket, pinion, sheave or pulley in meter
 K = factor

Overhung Member	K Factor
Sprocket	1.00
Spur Pinion	1.25
V-belt Sheave	1.50
Flat Belt Pulley	2.00

The calculated equivalent overhung load should be compared with the permissible values given in the table.

Maximum permissible overhung loads (Newtons) at centre of wheel shaft extension at 1500 r.p.m. Input Speed.

RATIO	BEARING NEAR SHAFT EXTENSION	SIZE OF UNIT																
		1 5/8	1 3/4	2	2 1/4	3	3.54	4	5	6	7	8	9	10	10.5	12	14	17
5	STD TRB	3080	3108	4840	4851	4857	4950	10454	12180	13636	15818	15900	16800	19550	19800	22310	34654	
	STD TRB+CRB					9216	10351	11720	15800	20963	22230	24225	24335	29800	29865	34650	50000	
7.5	STD TRB	3102	3080	4785	4796	5449	6600	11400	15090	16910	18900	19363	20010	21000	22820	27000	40500	
	STD TRB+CRB					9981	10351	13300	17600	24280	23450	26035	27110	32000	33340	36650	54975	
10	STD TRB	3102	3058	4708	4829	6151	7150	11120	16000	17636	19350	22335	22860	31000	26325	32909	49363	55000
	STD TRB+CRB					10769	11088	15593	19500	25450	25630	31400	32000	33000	33495	46636	69954	99000
15	STD TRB	2970	3047	4565	4400	7176	8272	10100	16620	17834	22300	24090	24000	28000	28300	33050	50875	63594
	STD TRB+CRB					11924*	13750*	16600*	20110*	26575*	27780*	32800	33000	40000	41000	55120	87089	130633
20	STD TRB	2893	2915	4400	4422	7877	9680	10252	15300	18014	23000	23800	26840	26700	27715	33000	52080	65100
	STD TRB+CRB					12841*	15400*	17481*	22800*	27220*	27980*	34600*	44825*	42000	44815*	57674*	92000*	138000*
25	STD TRB	2860	3135	4235	4345	8367	9295	10468	15545	18443	22250	24604	28600	28000	28900	32636	65270	78824
	STD TRB+CRB					12734*	16375*	17481*	24700*	27280*	29423*	35988*	47300*	47700	48800*	57004*	117068*	151025*
30	STD TRB	2723	2750	4043	4378	8848	9130	11061	15000	19816	21386	25520	30800	29000	29120	32800	67980	81576
	STD TRB+CRB					13165*	16500*	17914*	24400*	27468*	32373*	37769*	51150*	51000	51200*	57800*	127545*	172185*
40	STD TRB	2695	2723	4059	4428	9874	10450	12194	16618	22170	24035	29675	34650	29000	35325	31325	76726	88071
	STD TRB+CRB					14244*	17688*	18990*	25575*	30411*	37769*	41760*	52495*	50450	52015*	63272*	140745*	182968*
50	STD TRB	2778	2640	4180	4565	10468	10780	13165	17805	24133	25506	31078	36740	31000	33325	32080	83450	100148
	STD TRB+CRB					14838*	18832*	20126*	27366*	34335*	39710*	43812*	53000*	52700	53800*	63305*	154935*	185922*
60	STD TRB	2893	2873	4312	4758	11762	11110	13813	18830	25133	26880	32481	31195	30000	31800	34650	85535	102642
	STD TRB+CRB					16133*	20075*	20880*	29136*	37572*	42516*	45646*	53120*	53000	54000*	67630*	138050*	179465*
70	STD TRB	3025	3060	4928	5148	14028	13695	14513	19747	26389	29234	34100	35320	26000	30300	41580	86310	103572
	STD TRB+CRB					18345*	20350*	21474*	30269*	38357*	43066*	47696*	54000*	56045	57475*	70950*	143484*	186530*

* SPECIAL HEAT - TREATED SHAFT IS SUPPLIED

TRB = TAPER ROLLER BEARING
 CRB = CYLINDRICAL ROLLER BEARING

AVERAGE WEIGHT IN KILOGRAMS

Gear Size	1 5/8		1 1/4		2		2 1/4		3		3.54		4		5		6		7		8		9		10.5	
	NET	GR.	NET	GR.	NET	GR.	NET	GR.	NET	GR.	NET	GR.	NET	GR.	NET	GR.	NET	GR.	NET	GR.	NET	GR.	NET	GR.	NET	GR.
SNU-U	7	8.5	8	10.5	12	23	14	25	32	60	40	65	65	95	95	125	152	190	180	230	220	270	319	385	460	585
SNU-O	7	8.5	8	10.5	12	23	14	25	32	60	40	65	72	102	105	135	165	204	195	265	237	305	336	400	480	600
SNU-V	7.3	9	8.5	11.5	14	24	15	25	37	67	43	68	73	103	105	135	166	205	200	270	250	315	348	430	481	610
SNU-SM	-	-	-	-	15	28	16	28	35	65	41	66	64	80	110	140	157	170	200	270	252	316	330	415	465	590

APPROXIMATE OIL CAPACITY FOR SNU GEAR UNIT IN LITRES

	FILL AND FORGET									
SNU-U	2.5	2.5	4	5	9.5	11	16	21		
SNU-O	3.8	5.1	8	13.5	18	19	41	45		
SNU-V	3.5	4.0	5.7	8.5	18	20	25	26		

APPROXIMATE OIL CAPACITY FOR SNU-SM GEAR UNIT FOR DIFFERENT MOUNTING POSITIONS IN LITRES

	FILL AND FORGET									
A	4	5	7	10	18	19	41	45		
B	2.5	2.5	4	6	9.5	11	16	21		
C	2.5	2.5	4.7	8.8	18	20	25	26		
D/E	3	3.5	8	11.6	19	20	25	26		

		12	14	17	
SFU	Net Weight (kgs.)	580	885	1260	
	Gross Weight (kgs.)	900	1140	1700	
	Oil Capacity (ltrs.)	25	36	60	
SFO	Net Weight (kgs.)	660	940	1380	
	Gross Weight (kgs.)	920	1180	1800	
	Oil Capacity (ltrs.)	27	38	95	
SFV	Net Weight (kgs.)	660	870	1575	
	Gross Weight (kgs.)	845	1120	2000	
	Oil Capacity (ltrs.)	29	43	106	
SSM	Net Weight (kgs.)	780	1280	-	
	Gross Weight (kgs.)	940	1540	-	
	Approx. Oil Capacity in ltrs. For Diff. Mounting Positions	A	24	28	-
		B	22	25	-
		C	26	28	-
D/E		23	30	-	

- * Size 1 5/8 to 3 under 'FILL and FORGET' concept. i.e., Factory filled synthetic lubricant for lifetime lubrication
- * For higher sizes 3.54 to 17 first filling of oil is not supplied with the gear unit.
- * First change of oil should be made after 500 hrs. of operation.
- * Subsequent oil change must be made after every 3000 hours of operation. The interval should not exceed 12 months.

RECOMMENDED LUBRICANTS

I MINERAL OIL :

Brand	Grade
International Brands	
British Petroleum	CS 320 or GR-XP320
Castrol	Alpha Zn 320 or Alpha Sp-320 or Tribol 1100/320 TGQA
Caltex	Meropa 320
Esso Petroleum	Teresso 320 or Spartan 320
Fuchs	Renolin CKC 320
Mobil Oil Co.	Mobil DTE Oil AA or Mobilgear 632
Shell Co.	Vitera Oil 320 or Omela 320
Indian Brands	
Bharat Petroleum	Cabol 320
Balmer Lawrie Fuchs	Renolin CKC 320
Castrol	Alpha Zn 320 or Alpha Sp-320 or Tribol 1100/320 TGQA
Gulf	Gulf harmony 320 or Gulf EP 320
Hindustan Petroleum	Enklo 320 or Parthan EP 320
Indian Oil	Servomesh SP 320 or Servosystem 320
Veedol	Avalon 320

Recommended Grease : For low speed of operations.

Brand	Grade
Castrol	EPL 2
Indian Oil	SERVOGEM EP 2

II POLYGLYCOL BASED SYNTHETIC LUBRICANT

- * USE OF POLYGLYCOL BASED SYNTHETIC LUBRICANT IS ALSO ADVISABLE TO IMPROVE THE TRANSMITTING CAPACITY (RATING) OF GEAR UNITS MIN. 20% AS COMPARED WITH USE OF MINERAL OIL AT SAME WORKING TEMPERATURE. THIS GEAR OIL SHOWS EXCELLENT NON-AGEING STABILITY WITH FAVOURABLE INFLUENCE ON EFFICIENCY.

Approved Synthetic Lubricants

Brand	Grade
Castrol	Tribol 800-220
Fuchs	Renolin PG 220

Special Note : Synthetic Lubricants must not be mixed with any other type of oil. The gear unit must be flushed while changing to or from this lubricant.

MOUNTING POSITIONS AND SHAFT HANDING :

B – Breather plug
D – Drain plug

L – Oil Level indicator
G – Grease Nipple

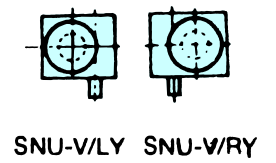
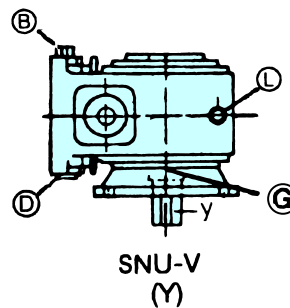
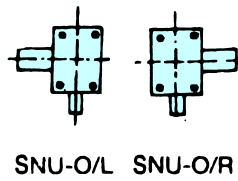
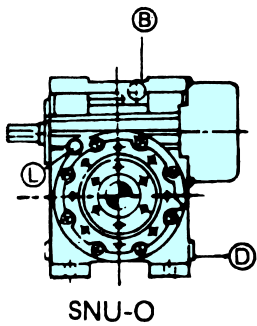
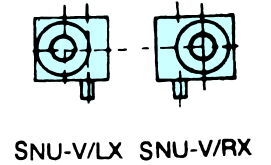
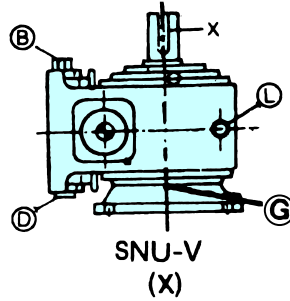
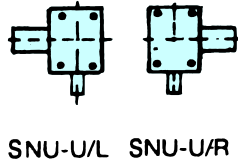
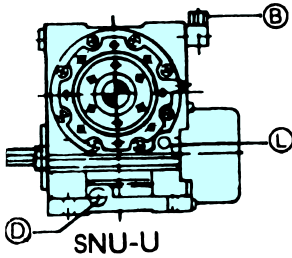

Replace (G) by plug for NU-V(X),V,(Y) in bottom side

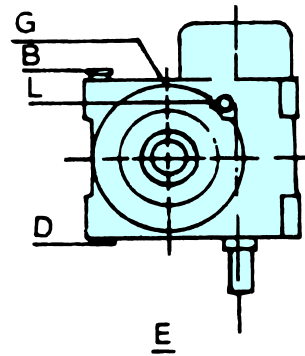
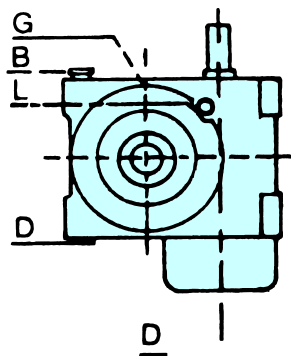
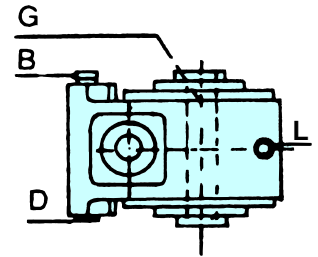
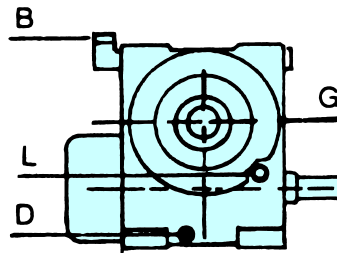
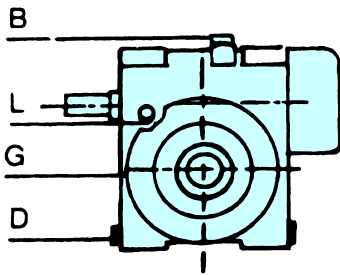

OPTIONAL STANDARD FEATURES

1. **SPRAG Holdbacks for Non-reversible Drives**

ELECON gear unit can be supplied, fitted with sprag holdback for non-reversible drives it is essential that the load or driven mechanism is prevented from running backwards after the driving motor is stripped e.g. inclined conveyors, elevator, winches etc.

The sprag holdback is incorporated on the fan end side of the high speed shaft. Visually and dimensionally the ELECON unit is unchanged. The hold back can be provided for either direction of rotation and the same should be specified when ordering.

2. **Base Frame**

Fabricated steel base frames are also supplied when requires.

3. **Steel Gearcases**

ELECON gear unit can be supplied with cast or fabricated steel cases for heavy duty application when loadings on the housings are in excess of the capacities of standard cast iron cases.

4. **Wormwheel construction**

Standard worm wheel comprise phosphorous bronze rims continuous welded to cast iron centres, where the duties demand rims are welded to steel centres.

5. **Slow speed shafts**

ELECON gear unit can be supplied with special slow speed shafts where required, These include units with special single extension, double extended shafts to the standard dimensions listed in this catalogue or special double ended extension. Additionally single or double ended shaft can be supplied in high tensile steel to heavy duty applications.

PRODUCT SAFETY INFORMATION

General ELECON gear units will operate safely provided that they are selected, installed, used and maintained properly. As with any equipment consisting of rotating shafts and transmitting power, adequate guarding is necessary to eliminate the possibility of physical contact with rotating shafts or couplings.

Potential Hazards The following points should be noted and brought to attention to the persons involved in the installation, use and maintenance of equipment.

1. For lifting of gear unit eye-bolts or lifting points (on larger units) should be used.
2. Check the grade and quantity of lubrication before commissioning. Read and carry out all instructions on lubricant plate and in the installation and maintenance manual literature.
3. Installation must be performed in accordance with the manufacturer's instruction and be undertaken by suitably qualified personnel.
4. Ensure the proper maintenance of gearboxes in operation. **USE ONLY ELECON SPARES FOR GEARBOXES.**
5. The oil level should be examined periodically, if required the oil should be filled again.
6. The operating speeds, transmitting powers, generated torques or the external loads must not exceed the design values.
7. The driving and the driven equipment must be correctly selected to ensure that the complete installation of the machinery will perform satisfactorily e.g. avoiding system critical speeds, system torsional vibration etc.

Any other required information or clarification can be obtained by writing to :

ELECON ENGINEERING CO. LTD.

POST BOX # 6, VALLABH VIDYANAGAR 388 120, GUJARAT, INDIA

TEL.: +91-2692-236513, 236520, 232890 FAX : +91-2692-236527

E-MAIL : infogear@elecon.com

Web Site : <http://www.elecon.com>

As improvement in designing are continuously being made, the details and dimensions are subject to alteration without notice.

ELECON RANGE OF PRODUCTS

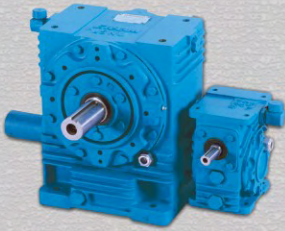

SNU-UD-DOUBLE REDUCTION WORM GEAR UNIT

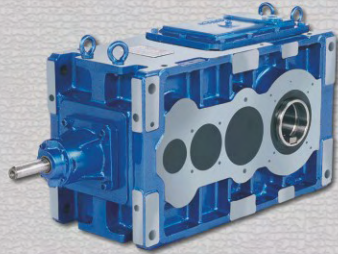

EP-SERIES HELICAL / BEVEL HELICAL GEARS



FLUID - GEARED & FLEXIBLE COUPLINGS

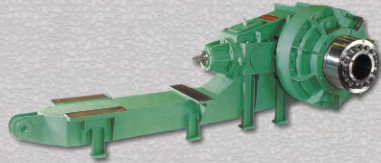

PLANETARY BUCKET WHEEL GEAR BOX

MARKETING & SERVICING COMPANY



EMTICI ENGINEERING LIMITED

REGISTERED OFFICE :

Anand - Sojitra Road, Vallabh Vidyanagar - 388 120, Gujarat, INDIA. Phones : +91 269 223 0168, +91 269 223 1125 Fax : +91 269 223 6508
Website : www.emtici.co.in

NATIONAL BRANCHES :

AHMEDABAD :

Phone : +91 792 640 6685, +91 792 640 6686
Fax : +91 792 640 1363
E-Mail : sales@ahmemtici.elecon.com

BANGALORE :

Phone : +91 802 225 0082, +91 802 226 0219
Fax : +91 802 228 1834
E-Mail : salesbgl@bglemtici.elecon.com

INDORE :

Phone : +91 731 257 6100, +91 731 255 8077
Telefax : +91 731 257 6100

MUMBAI :

Phone : +91 222 282 1315, +91 222 282 0725
Fax : +91 222 287 0791
E-Mail : salesbom@bomemtici.elecon.com

NEW DELHI :

Phone : +91 112 341 4339, 4340, 4341
Fax : +91 112 370 9046
E-Mail : salesdel@delemtici.elecon.com

ASANSOL :

Phone : +91 341 220 5901, +91 341 221 1726
Fax : +91 341 220 2038
E-Mail : salesasn@asnemtici.elecon.com

CHENNAI :

Phone : +91 442 434 9497, +91 442 434 9237
Fax : +91 442 434 9643
E-Mail : salesmad@mademtici.elecon.com

JAMSHEDPUR :

Phone : +91 657 246 4241, +91 657 236 1837
Fax : +91 657 246 4241
E-Mail : sales_jns@jnpemtici.elecon.com

MADURAI :

Phone : +91 454 929 3488
E-Mail : salesmad@mademtici.elecon.com

PUNE :

Phone : +91 202 614 1795
Fax : +91 202 614 1793
E-Mail : salespune@puneemtici.elecon.com

VADDARA :

Phone : +91 265 231 2972, +91 265 231 2980, Fax : +91 265 231 2980
E-Mail : salesbrd@brdemtici.elecon.com

BILASPUR :

Phone : +91 775 222 8922, +91 775 222 4122
Fax : +91 775 222 3188
E-Mail : salesbil@bilemtici.elecon.com

DHANBAD :

Phone : +91 326 230 6283, +91 326 230 2320
Fax : +91 326 230 2320
E-Mail : salesdhn@dhnemtici.elecon.com

KOLKATA :

Phone : +91 332 476 1861, +91 332 476 0876
Fax : +91 332 476 1831
E-Mail : salescal@calemtici.elecon.com

NAGPUR :

Phone : +91 712 664 2600
Fax : +91 712 664 2622
E-Mail : salesnag@nagemtici.elecon.com

SECUNDRABAD :

Phone : +91 402 784 4748, +91 402 784 5250
Fax : +91 402 784 8317
E-Mail : salessec@secemtici.elecon.com

INTERNATIONAL BRANCHES :

FAR EAST :

ELECON SINGAPORE PTE. LTD.
Phone : +65 622 782 58
Fax : +65 622 789 42
E-Mail : sales@singapore.elecon.com
tejas@singapore.elecon.com

SOUTH AFRICA :

ELECON AFRICA PTY. LTD. :
Cell : +27 82900 6829
+ 27 832940291
E-Mail : gdramsay@mweb.co.za

MIDDLE EAST :

ELECON MIDDLE EAST FZCO
Phone : +97 146 091 424, +97 146 091 425
Fax : +97 146 091 426
E-Mail : rajen@dubai.elecon.com
milap@dubai.elecon.com
nirav@dubai.elecon.com



Always a step ahead in technology

Manufactured by :

ELECON ENGINEERING CO. LTD.

Post Box # 6, Vallabh Vidyanagar - 388 120, Gujarat, INDIA

MHE DIVN. : Tel. : +91 269 223 7016, +91 269 223 6521, +91 269 223 6590 Fax : +91 269 223 6457 E-mail : infomhe@elecon.com

GEAR DIVN. : Tel. : +91 269 223 6469, +91 269 223 6513, +91 269 223 6516 Fax : +91 269 223 6427 E-mail : infogear@elecon.com

Website : www.elecon.com